

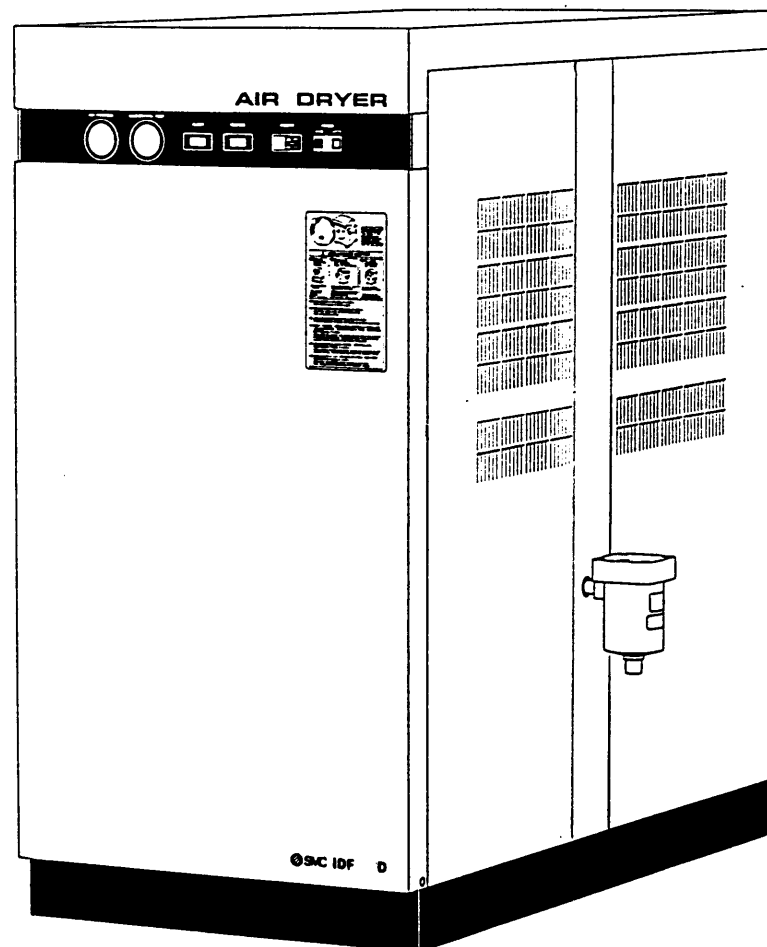

REFRIGERATED AIR DRYER

IDF240D-3

Operation Manual



Thanks for purchasing SMC Refrigerated Air Dryer. This operation manual must be read thoroughly before any operation of product. It provides all essential information for maximizing product operating efficiency, as well as, for longer life span operation. Keep it properly, as long as it is in use, for any necessary reference.

CAUTIONARY POINTS FOR SAFETY USAGE

For safety operation of SMC Refrigerated Air Dryer, read thoroughly below stated safety cautionary notes, as well as regulation stated within ISO 4414*¹ & JIS B 8370*². With the conscious of regulation stated and follow them closely.

Cautions : Stated content shows cautionary notes for mishandling, which would lead to the danger of harming people or damaging of things.

*1. ISO 4414 : Pneumatic Fluid Power – Recommendations of the application of equipment to transmission and control system.

*2. JIS B 8370 : General Rule for Pneumatic System.

CAUTIONS

INSTALLATION

1. Ensure enough ventilation space. Insufficient of ventilation space would lead to problems of insufficient cooling and abnormal stoppage of air dryer.
2. Follow strictly instruction given in Section 2 "Installation".

PIPING

1. Drain extraction port must be installed at the bottom of rising pipe line. Air piping must be at an incline with drain extraction valve installed at end line to prevent any collecting of drain.
2. Be aware of not to mistaken compressed air IN·OUT port. Mistaken of port would lead to the flow of water vapor to down stream.

WIRING

1. Appropriate residual current operated circuit breaker must be selected based on product's capacity and residual current capacity to prevent any electrical shock and burnt of compressor. Refer to Section 9-3 "Specification".
2. Do not use voltage other than specified, which would lead to fire and electrical shock. Voltage variation must be within $\pm 10\%$.
3. Do not perform any changes of electrical wiring of air dryer, which would lead to malfunction of electrical parts and product.

AIR SOURCE

1. Do not use working fluid other than compressed air.
2. Do not use compressed air that contains of chemical, organic solvent or corrosive gas, which would lead to the leakage of refrigerant from heat exchanger.
3. Air tank should be installed in front of air dryer, if there is any pulsating of compressor air, which would cause the damage of heat exchanger chamber.

MAINTENANCE & OTHERS

1. There is danger of electrical shock by bare electrical parts or connection. Maintenance must only be carried out after the cut off of power supply.
2. Immediate after operation of air dryer, compressor and parts of refrigeration piping is in high temperature state. Maintenance must only be performed after the cool down of high temperature parts to prevent from any burnt or hurt of personnel.
3. Ones should aware that there is rotating parts (fan) within air dryer. Therefore, ones is not allowed to insert or put any rods, particles, including hands, within sheet panel of air dryer.
4. The exchange of auto drain, pressure gauge and the maintenance of drain piping must only be performed under depressurized condition.
5. Refrigeration piping is operating under high temperature & high pressure condition. Any maintenance involving refrigeration piping must be performed by professionals.
6. Air dryer is used to dehumidify compressed air. Apart from this particular usage, the manufacturer shall not be

liable for any claims, damage arisen due to misused of the product.
 7. Air dehumidified by air dryer is not suitable for breathing without further purification.

LABEL



- Ensure power supply is cut off and fan motor installed within product is not rotating, whenever performing any maintenance or replacing of parts.

TABLE OF CONTENTS

1. OUTLINE	1
1-1. Preface	1
1-2. Transportation / Handling	1
1-3. Confirmation	1
2. INSTALLATION	1
2-1. Electrical Wiring	2
2-2. Auto Drain Installation	2
3. OPERATION	2
3-1. How to Operate	2
3-2. Operation	2
3-3. Noise	2
3-4. Compressed Air and Refrigerant Circuit	2
4. DISPOSAL	2
5. MAINTENANCE	2
6. ADJUSTMENT	3
6-1. Capacity Regulating Valve & Pressure Switch	3
6-2. Thermostatic Expansion Valve	3
6-3. Sight Glass	3
7. TROUBLESHOOTING	4
8. SPARE PARTS LIST	5
9. REFERENCES	6
9-1. External Dimensions	7
9-2. Electrical Circuit	8
9-3. Specification	8
9-4. Compressed Air and Refrigerant Circuit	8
9-5. How to Disassemble Auto Drain	9

Caution : Content specified within this operation manual are subjected to change without prior notice and any obligation on the manufacturer. Please refer to operation manual attached with product for up-to-date information.

1. OUTLINE

1-1. Preface

SMC Refrigerated Air Dryers remove moisture from compressed air to satisfy the industrial requirements for compressed air purification. Refrigerant circuit with employing capacity regulating method allows long period of continuous operation. It uses refrigerant, R407C, which has the characteristics of Ozone Depletion Potential (ODP) of ZERO.

1-2. Transportation / Handling

- Neither lays the product horizontally nor drops it onto floor.
- Use forklift for transportation.
- Do not install air dryer at outdoors. It is not designed for outdoor installation.
- Unpack air dryer only at places near to installation spot. Be aware of not to transmit any vibration to internal parts of air dryer during handling.

1-3. Confirmation

After unpacking, carefully check whether accessories specified below are attached and whether received product appearance is in good condition. If there is any damage, contact one of our agents immediately for investigation. Note : Use the unit serial number, marked on the data plate at the top panel, as reference when inquiring. **DO NOT** attempt to repair it since installation or trying to repair any damage of equipment or components may cause the warranty to be invalid and/or may cause personal injury.

Accessory	Qty.
ADH4000-04	1
Nipple (PT 1/2)	1

2. INSTALLATION

- (1) Mount air dryer at **rigid and flat** surface. Flatness of surface level should be within 5° .
- (2) Keep air dryer a **minimum clearance of 1m** away from surroundings or obstacles to ensure enough ventilation and ease of maintenance.
- (3) Install air dryer in well ventilated room, which should be in **less dust and lower humidity** condition.
- (4) Connection of **Main Line Filter**, AFF Series, at the inlet of air dryer is recommended to prevent from inducing of oil mist, particles, etc., which would lead to malfunction of auto drain and other internal parts.
- (5) Install bypass piping to ease of maintenance. With that, there is not any necessary to stop air compressor, even during maintenance of air dryer is carried out.
- (6) Do not install air dryer and air compressor at places where atmosphere contains acid or chemicals. Sulfur dioxide, hydrogen sulfide and ammonia gas is severely prohibited.

2-1. Electrical Wiring (Please refer to Section 9-2, 'Electrical Circuit')

- For safety purposes, air dryer should be connected to power supply that is attached with circuit breaker. .
- Power Supply Specification,

Three Phase AC180~220V±10% 50Hz

Three Phase AC180~242V±10% 60Hz

Inter-phase unbalance rate should be kept within 3%.

- Remove front panel. Then, connect power cord as well as grounding wire to terminal block as shown in figure 2-1.
- Use only power and grounding wire as shown in table 2-1.

Table 2-1

Model	Power Cord / Grounding Wire Cord size, mm ²	Remote Control / Signal Wire Cord size, mm ²
IDF240D	5.5	0.5

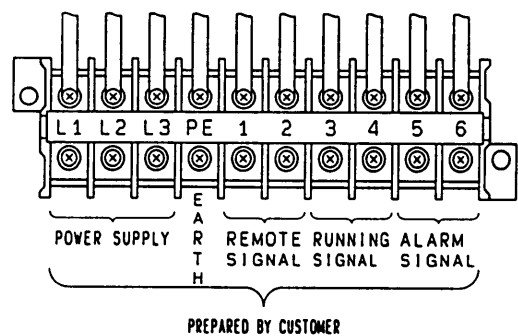

Figure 2-1 Terminal Block

2-2. Auto Drain Installation

- Auto drain and nipple joint, which are provided together with air dryer, should be connected to air dryer's drain outlet prior to use. Seal tape should be used for more securely fastening and prevent from air leakage. Make sure to use spanner to hold shutoff valve to avoid torque to the drain pipe during installation. Check all the connections for air leakage. Remedy if any.
- Connect drain tube to auto drain outlet. Connected drain tube should be at **internal diameter of 8mm or more and length of 10m or less**. Drain tubing should be in **straight and downward** position. It should not be raised up or bent during used.
- Ensure shutoff valve at drain tube is kept opened all the times.

3. OPERATION (Please refer to Section 9-3, 'Specification')

3-1. How to Operate

- Before operating air dryer, check the following items :-
 - i. Compressed air inlet valve leading to air dryer is closed, so as to stop the flow of compressed air.
 - ii. Power supply should stays within allowable range.
 - iii. Installation is performed properly based on description in Section 2, 'Installation'.
- Starting and stopping air dryers with ON/OFF switch only.
- If stoppage of air dryer occurs, resume operation only after an interval of three minutes.
- To obtain highly humidified air, ones must always start the operation of air dryer before the starting of air compressor, as well as, stop the operation of air compressor before stopping air dryer.

3-2. Operation

- Product is well calibrated before outgoing from factory. It should perform at its best efficiency if care is taken during its installation and transportation.
- Utilize it within allowable operating condition range.
- Follow description in Section 5. 'Maintenance' for regular inspection to achieve its best operating efficiency.

3-3. Noise

The measured noise level is 70dB(A) or less under condition specified in ISO 131.

3-4. Compressed Air and Refrigerant Circuit

Refer to Section 9-5.

4. DISPOSAL

Before disposed of air dryer, refrigerant and compressor lubricant should be removed. Check local and state law during disposal of refrigerant and compressor lubricant.

5. MAINTENANCE

Make a preventive maintenance schedule, which is described in the table 5-1, and follow it closely, so as to ensure continuing good performance and safe operation of air dryer.

Table 5-1

Daily Inspection	
Run lamp	Run lamp shall turn on whenever air dryer starts its operation.
Evaporation Thermometer	Evaporation thermometer pointer should always stay within green band whenever compressed air is flowing.
Auto Drain	Condensed moist collected within auto drain discharges periodically by itself. If not, disassemble the auto drain and perform cleansing following description specified in Section 9-5, "How to Disassemble Auto Drain"
Monthly Inspection	
Condenser	Check whether dust accumulates at condenser fin. If it does, use vacuum cleaner, air blow nozzle or brush to clean affected area. Always keep it in clean state.

6. ADJUSTMENT

6-1. Capacity Regulating Valve

Capacity Regulating valves and pressure switches are set at specified values shown in table 6-1, before outgoing from factory. Therefore, further adjustment is usually not required during initial operation.

Table 6-1

Description	Adjusting Range	Remarks
Capacity Regulating Valve	1~5°C (0.43~0.49MPa)	Reading from evaporation thermometer. Adjustment is possible. Follow instruction below.
Pressure Switch	OFF : 1.7MPa ; ON : 1.4MPa	Fixed adjustment.

For circumstances whereby the adjustment of capacity regulating valve is required, follow the instruction specified in table 6-2 to perform adjustment during no load operation ^{note 1}. Furthermore, confirm whether the pointer of evaporation thermometer is within green zone region during load condition ^{note 2}. If the pointer is under or over the green zone region, repeat the adjusting process. If adjusting target could not be achieved, contact our nearest sales offices or authorized dealers.

Table 6-2

Evaporating Temperature, °C	Adjusting Method ^{note 3}
Below 1°C	Remove cap fastened at the above of capacity regulating valve. Then, use spanner to turn the square adjusting rod in clockwise direction.
Above 5°C	Remove cap fastened at the above of capacity regulating valve. Then, use spanner to turn the square adjusting rod in anti-clockwise direction.

- Note :
1. "No Load Operation" refers to the operating condition whereby no air flows through air dryer.
 2. "Load Operation" refers to the operating condition whereby air flows through air dryer.
 3. The stabilization of temperature takes gradually. Turn half a turn of the square adjusting rod each time at an interval of 5 minutes before obtaining appropriate reading.

6-2. Thermostatic Expansion Valve

Thermostatic expansion valve is used to control the flow of refrigerant to achieve appropriate cooling of compressed air to ease of drain separation. It is set to maximize product's performance, before outgoing from factory. Therefore, no adjustment is allowed unless advised by SMC technical personnel.

6-3. Sight Glass

The purpose of sight glass is to ease the confirmation of refrigerant condition.

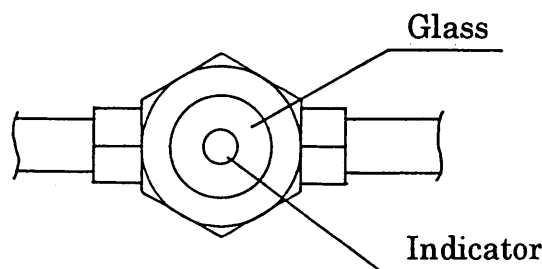

Figure 6-1 Sight Glass

(a) Confirmation of Refrigerant Charge

Table 6-3

Sight Glass	Condition
A lot of liquid flowing through	Normal
Liquid with bubble	Normal
A lot of bubble	Refrigerant may be insufficient
Separation of liquid and gaseous level	Refrigerant is insufficient

(b) Confirmation of Water Content in Refrigeration Circuit

It could be recognized by checking the indicator pasted on the above of sight glass.

Green (DRY condition) : Normal.

Yellow (Wet condition) : Mixture of water vapor occurs.

With water vapor mixed in refrigeration circuit, degrading of compressor lubricant and faulty operation of other control elements could occur and lead to the malfunction of refrigerated air dryer.

7. TROUBLE SHOOTING

Should any problem occur, inspect it with reference to the following table. If problems cannot be solved, remove the power source and contact with our nearest sales offices or authorized dealers.

Problem	Possible Causes	Remedy
Air dryer does not operate and running lamp does not light on, even switch is ON.	Power cord or plug is in loosening state.	Perform proper connection on the power cord and plug.
	Circuit breaker is OFF.	Check whether proper capacity of circuit breaker is connected. Resume the operation after resetting the circuit breaker to ON position. If the circuit breaker still trips to OFF, failure of electrical insulation may have occurred. Cut off power supply and contact one of our agents for instructions.
	Blown of fuse.	Replace fuse.
Lamp extinguishes and refrigerant compressor stops during operation. Or, Fan runs continuously.	Installation place is poorly ventilated. Ambient temperature is too high.	Improve ventilation in order to lower the ambient temperature.
	Right or left portion of the ventilation grille is obstructed by the wall or clogged by dust. Condenser is clogged by dust, oil mist, etc.	A minimum of 1m clearance should be provided for both sides of air dryer. Clean ventilation grille and condenser at least once a month.
	Inlet compressor air temperature is too high.	Provide better ventilation at area near to air compressor and lower down its ambient temperature. Install after cooler.
	Supply voltage does not fall within operating range specified in Section 2-1.	Set the voltage to the proper value by using a transformer or review the electrical wiring.
Temperature shown on evaporation thermometer is higher than green zone marked.	Installation place is poorly ventilated. Ambient temperature is too high.	Improve the ventilation and lower the ambient temperature.
	Right or left portion of the ventilation grille is obstructed by the wall or clogged by dust. Condenser is clogged by dust, oil mist, etc.	A minimum of 1m clearance should be provided for both sides of air dryer. Clean ventilation grille and condenser at least once a month.
	Inlet compressor air temperature is too high.	Provide better ventilation at area near to air compressor and lower down its ambient temperature. Install after cooler.
	Confluence of piping with another unit without air dryer.	Install another dryer to the unit. Separate these two units.
Large pressure drop.	Bypass valve of air dryer is not fully opened.	Open it fully.
	Filter, which is installed either at front or back of air dryer is clogged.	Replace the filter element. (Follow the instruction manual of each and individual devices.)

Problem	Possible Causes	Remedy
Moisture is produced in downstream.	Bypass valve of air dryer is not fully opened.	Open it fully.
	Drain is not discharged properly from auto drain.	Check whether drain tubing is raised up or bent. Disassemble and clean auto drain. Check whether ball valve at drain outlet is fully opened.
	Mixed with compressed air from the other piping system that does not have air dryer.	Either install air dryer at the other compressor air system, or do not mix with the compressor air system.
Drainage or air continues to blow out from drain discharge port.	Working pressure is 0.15MPa (1.5kgf/cm ²) or lower.	Confirm the working pressure.
	Hole of orifice plate is clogged.	Disassemble and clean auto drain.
	Valve inside the auto drain is damage.	Replace the valve.
	'O' ring of auto drain is damage.	Replace the 'O' ring.
	Cap is clogged.	Disassemble and clean auto drain.
Auto drain is not fitted in vertical position.	Fit the auto drain in vertical position.	

8. MAINTENANCE PARTS LIST

The following table shows the parts list for maintenance. Please inquire quotation before making parts ordering.

Part No.	Description	Quantity
ZR90K3E-TWD	Compressor	1
UC4-153BP	Fan Motor	2
SC-2N	Magnetic Contactor	1
BMM663302	Magnetic Contactor	1
A-232-GF	Running Lamp	1
A-232-RF	Alarm Lamp	1
DS-430W	ON Switch	1
DS-431B	OFF Switch	1
AH164-SL5Y11M1	Remote Selector	1
THC-10KN3A	Fuse	1
ADX11125	Timer Relay	1
AP3125K	Relay	1
AP3145K	Relay	1
GK25-S24-01	Pressure Gauge	1
GK25-S24-10	Evaporation Thermometer	1
ACB-IA14	Pressure Switch	1
CPHE-4	Capacity Regulating valve	1
HFES5-1/2HC	Thermostatic Expansion Valve	1
80303515131001	Accumulator	1
FTB-Z327	High Pressure Switch	1
LTB-A303	Low Pressure Switch	1
EK-164S	Filter Dryer	1
4031399	Flange Attached Cooler	3
ADH4000-04	Auto Drain	1

9. REFERENCES

9-1. External Dimensions

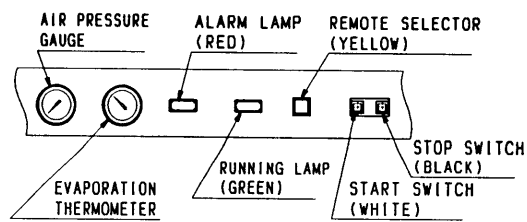
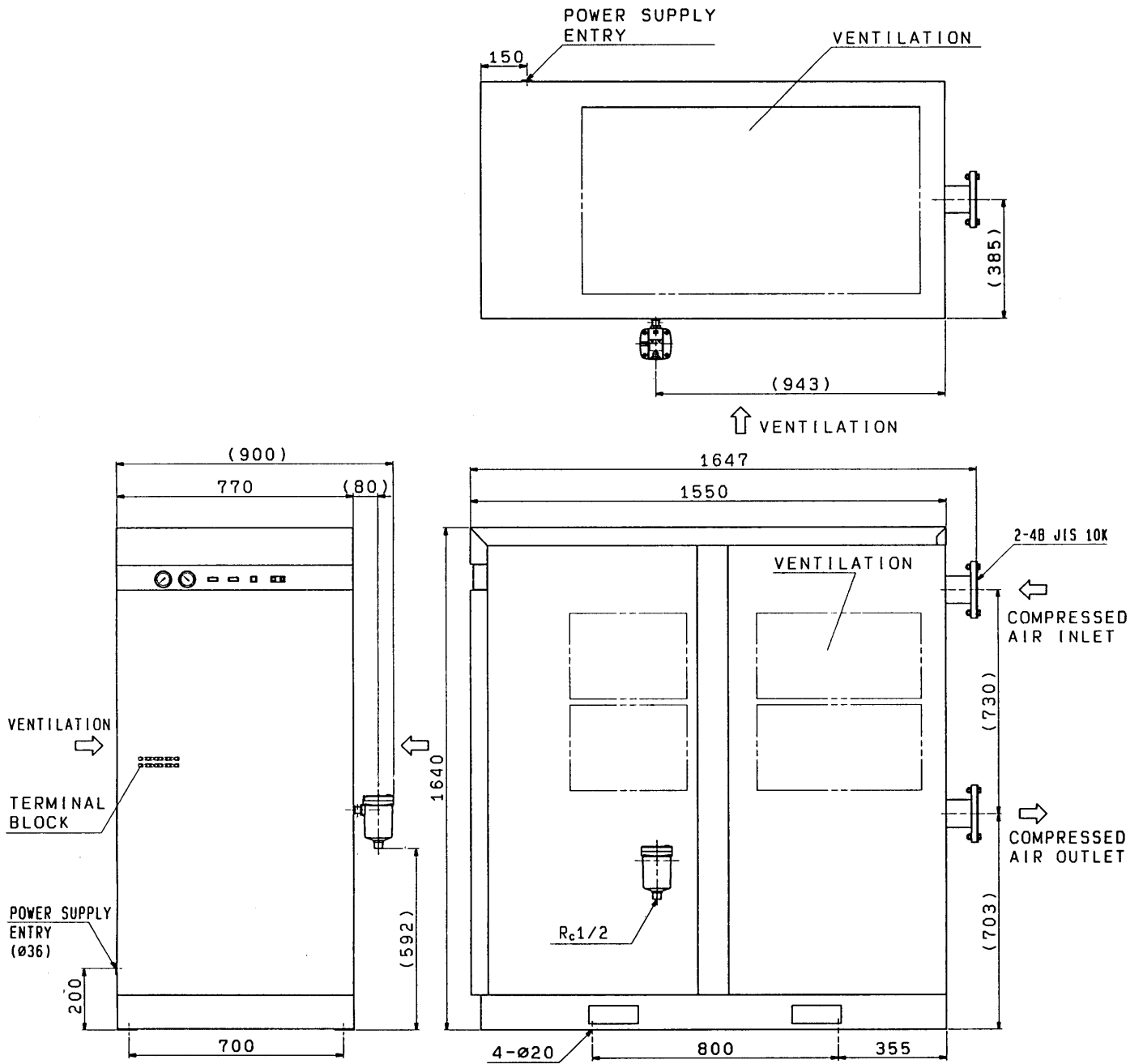

MINI FRONT PANEL DISPLAY DETAIL

9-2. Electrical Circuit

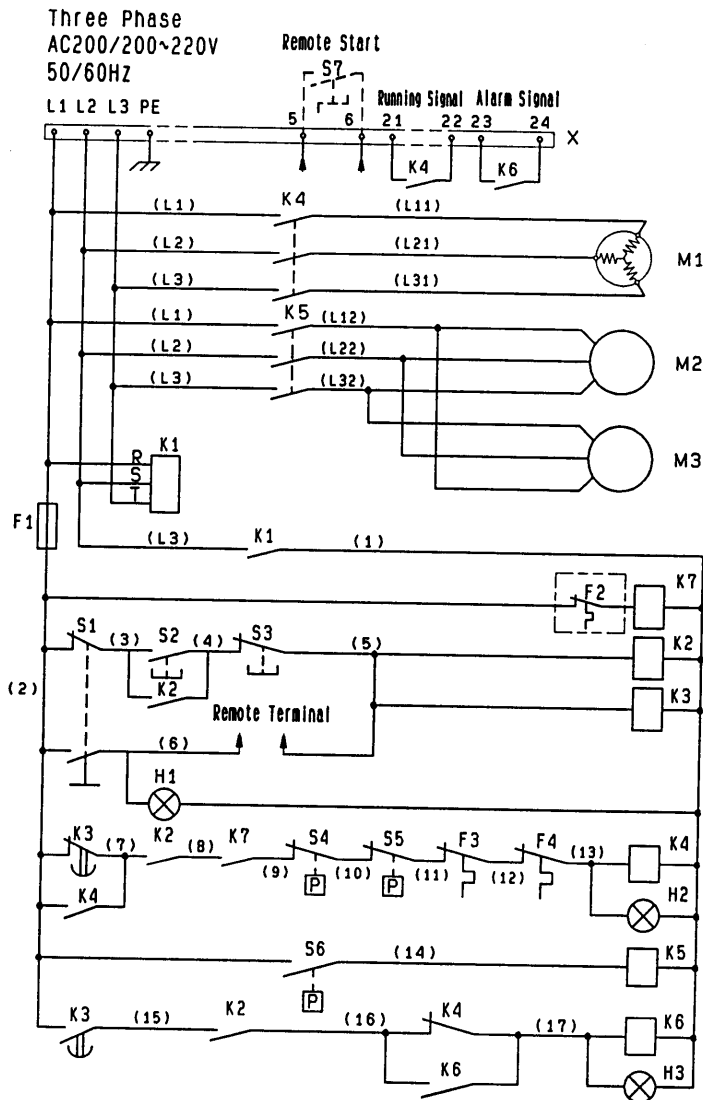

SYM.	NAME
M1	COMPRESSOR
M2, 3	FAN MOTOR
K1	REVERSAL PHASE RELAY
K2, 6	RELAY
K3	TIMER RELAY
K4, 5	MAGNETIC CONTACTOR
K7	PROTECTOR RELAY
S1	REMOTE SELECTOR
S2	START SWITCH
S3	STOP SWITCH
S4	HIGH PRESSURE SWITCH
S5	LOW PRESSURE SWITCH
S6	PRESSURE SWITCH
S7	REMOTE START SWITCH
F1	FUSE
F2	MOTOR PROTECTOR(M1)
F3	MOTOR PROTECTOR(M2)
F4	MOTOR PROTECTOR(M3)
H1	REMOTE RUNNING LAMP
H2	RUNNING LAMP
H3	ALARM LAMP
X	TERMINAL BLOCH

S4:HIGH CUT 2.5MPa

S5:LOW CUT 0.2MPa

S5, F2, F3, F4:
AUTOMATIC RESET TYPE

S4:MANUAL RESET TYPE

F2:30min AUTOMATIC RESET TYPE

9-3. Specification

Specification		Model	IDF240D-3
Rated Condition	Air Flow Rate	50Hz	43 m ³ /min (ANR)
		60Hz	50 m ³ /min (ANR)
	Operating Pressure		0.7 MPa
	Inlet Air Temperature		40 °C
	Ambient Temperature		32 °C
	Pressurized Dew Point		10 °C
Operating Range	Working Fluid		Compressed Air
	Inlet Air Temperature		5~50 °C
	Inlet Air Pressure		0.15~1.0 MPa
	Ambient Temperature		2~40 °C (Relative Humidity of 85% or less)
Electrical Specification	Power Source		Three Phase, AC200 / 200~220V (50/60Hz)
	Power Consumption	50Hz	6.3 kW
		60Hz	7.5 kW
	Operating Current	50Hz	26.1 A
		60Hz	26.9 A
Circuit Breaker		60 A	
Condenser			Air Cooled
Refrigerant			R407C
Refrigerant Charge			4500 ± 30 g
Air Connection			4B Flange
Drain Connection			Rc ½
Auto Drain			ADH4000-04
Mass			600 kg
Applicable Compressor (for screw type)			240 kW

Note 1) The data for l/min (ANR) is referring to the conditions of 20°C, 1atm. pressure & relative humidity of 65%.

Note 2) Install circuit breaker that comes with sensitivity of $\leq 30\text{mA}$.

9-4. Compressed Air and Refrigerant Circuit

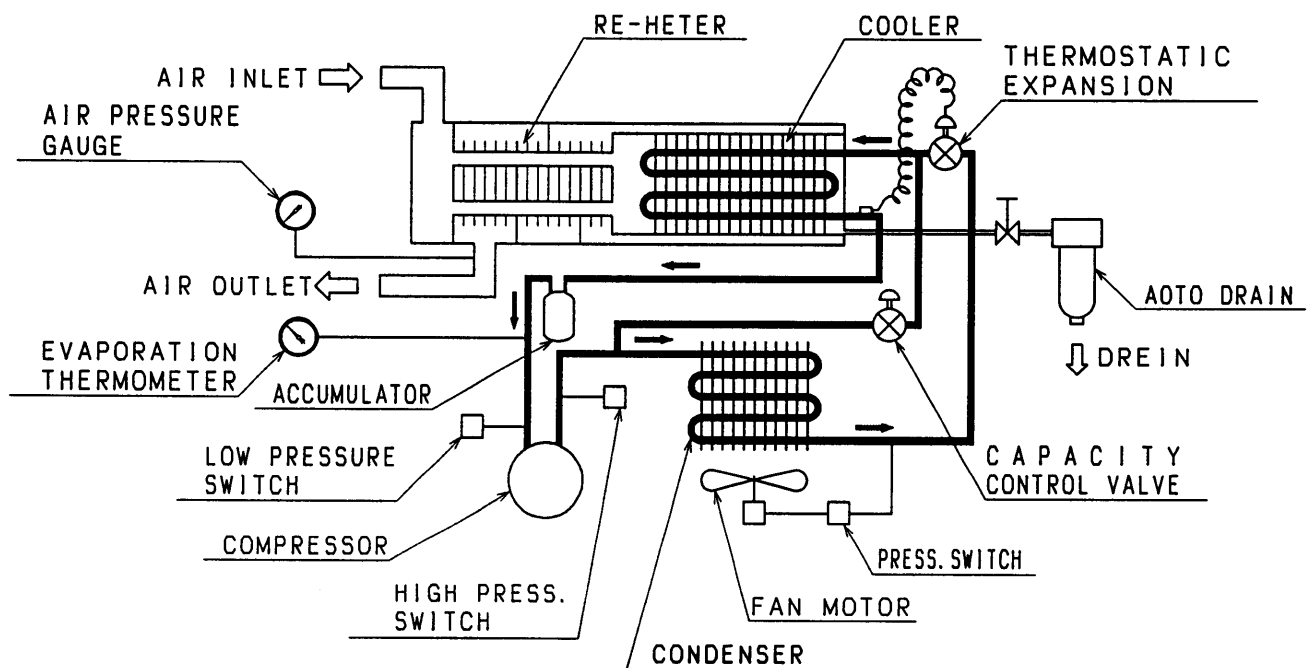

9-5. How to Disassemble Auto Drain

Cautions : Whenever disassembling of auto drain is involved for maintenance or any other purposes, below stated procedures must be followed strictly, so as to relief residual air pressure.
Disassembly of auto drain should not be performed under pressurized condition.

- * How to Depressurized, refer to Figure 1
 Shut off the ball valve installed in front of auto drain. Release air pressure gradually through bleed valve. When bleeding of compressor air stops, press flush button to release residual pressure.

(A) Disassemble Method, refer to Figure 2

Use wrench (Allen Keys) with nominal size of 5 to dismantle 4 pcs. of hexagonal cap screws. Take off body together with drain mechanism section from housing.

(B) Cleaning of Internal Parts

- (1) Hold firmly the body. Soak drain mechanism section into ***water mixed with neutral detergent or warm water*** to wash away dirt.

Cautions : Do not use hot water, as well as corrosive solvent. Drain mechanism section must not be dismantled.

Whenever any flaws are found at exhaust valve & valve seat, and dust & contaminant could not be washed away from it, it has to be exchanged. Follow instruction stated in (D) to perform the exchange.

- (2) Clean, dry and wax the internal surface of housing. With foreign particles, leakage may occur after re-assembling.
- (3) If dirt or foreign particles are found on "O" ring, clean it gently and apply a thin layer of grease. Check whether there is any flaws or deformed of shape, as they would lead to leakage after re-assembling. Replace it by new part.

"O" ring part number : G85(B)

(C) Re-Assembly of Auto Drain

- (1) Insert "O" ring properly and gently into groove at the top of housing. ***Be aware of protrusion of "O" ring.***
- (2) Hold the body with drain mechanism section at below. Put the assembly gently into housing with flush button at the opposite of drain inlet. At the final inserting gap of 3mm, there would have difficulty in direct forcing in. As such, adjust housing to fit into body assembly.

- (3) Insert 4 pcs. of hexagonal cap screws and fastening them tightly by applying fastening torque of 50 kgf/cm.

Cautions : Ensure that there is no gap in between housing and body, when performing the fastening of bolts. Fastening with the exit of gap would lead to damage of parts.

- (4) After re-assembling of auto drain, connect it back to the drain outlet of air dryer. Ensure that there is no leakage of air from piping connection.

(D) Orifice Cleaning Method

Clean orifice when it clogs.

- (1) Close ball valve. Depressurize auto drain.
- (2) Remove exhaust cover. Take orifice cleaning pin placed on the reverse side of exhaust cover.
- (3) Orifice is located in the center of body. Insert pin into the hole of orifice and remove dust.
- (4) Open ball valve at the drain inlet slowly.
- (5) Check if air is exhausted from orifice by pressing flush button. If air still goes on discharging, repeat from step 3.
- (6) Mount exhaust cover.

(E) Exchange of Exhaust Valve

Order below stated exhaust valve maintenance kit (ADH-D400) to perform necessary maintenance. Read replacement manual attached with the maintenance kit, before executing the exchange.

Cautions : Special tool is required to perform the exchange of exhaust valve. Follow strictly procedures stated in the replacement manual.

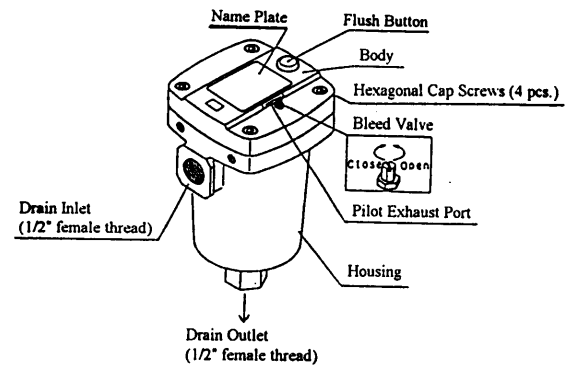

Figure 1 : Parts Description

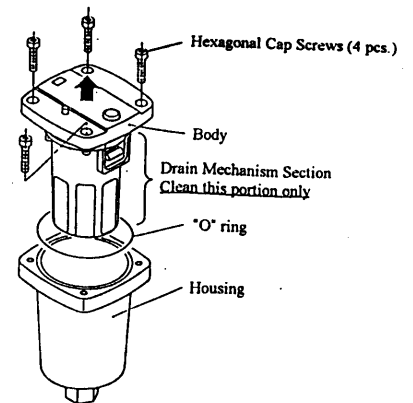

Figure 2 : Disassembling Diagram

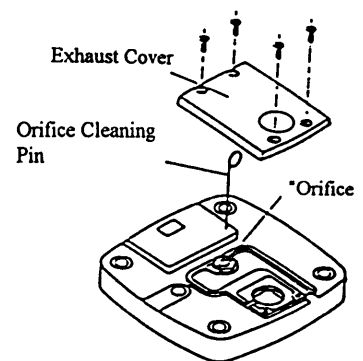

Figure 3 : Orifice Cleaning