



---

---

# OPERATION MANUAL

---

PRODUCT NAME: Ionizer

MODEL: IZS31 Series

---

---

---

---

---

---

---

---

---

---

- Read this operation manual carefully to understand the product before installation and operation.
- Pay extra attention to the clauses concerning safety.
- Keep this operation manual available for future reference.

## INDEX

1. Safety instructions.....	2
2. Installation .....	5
2-1. Installation of Ionizer body .....	5
2-2. Installation of Feedback Sensor and Auto Balance Sensor [high precision type and body mounting type].....	7
2-3. Connection of cables.....	9
3. Function description.....	9
3-1. Operation mode .....	9
3-2. Detection of contamination on the electrodes.....	10
3-3. Indication / Setting part description.....	10
4. Selection and setting of equipment.....	11
4-1. Sensing DC mode .....	11
4-2. Pulse DC mode .....	14
4-3. DC mode .....	19
4-4. Power supply cable connection circuit.....	21
5. Specifications .....	23
5-1. Ionizer.....	23
5-2. Sensor.....	24

## 1. Safety instructions

- This manual contains essential information for the protection of users and others from possible injury and/or equipment damage.
- Read this manual before using the product, to ensure correct handling and read the manuals of related apparatus before use.
- Keep this manual in a safe place for future reference.
- These instructions indicate the level of potential hazard by label of "DANGER", "WARNING" or "CAUTION", followed by important safety information which must be carefully followed.
- To ensure safety ISO 4414 and JIS B 8370, "Pneumatic fluid power – General rules relating to systems", must be observed along with other relevant safety practices.



**DANGER:** In extreme conditions, there is a possibility of serious injury or loss of life.



**WARNING:** If instructions are not followed, there is a possibility of serious injury or loss of life.



**CAUTION:** If instructions are not followed, there is a possibility of injury or equipment damage.

- 1) ISO 4414: Pneumatic fluid power - General rules relating to systems
- 2) JIS B 8370: Pneumatic fluid power - General rules relating to systems  
Recommendations for the application of equipment in transmission and control systems.



### WARNING

#### 1. The compatibility of equipment is the responsibility of the person who designs the systems or decides the specifications.

Since the products specified here can be used in various operating conditions, their compatibility with the specific system must be based on specifications or after analysis and/or tests to meet your specific requirements. Those who decide the compatibility of equipment shall take the responsibility to guarantee the initial system performance and safety. Construct the system after reviewing all the specifications in the latest catalogue or documentation, as well as, considering the possibility of equipment in every application.

#### 2. Only trained personnel should operate machinery and equipment.

This product generates high voltages, therefore it can be dangerous if an operator is unfamiliar with it. Assembly, handling or repair of systems should be performed by trained and experienced personnel.

#### 3. Do not service machinery/equipment or attempt to remove components until safety is confirmed.

- 1) Inspection and maintenance of the machinery and equipment should be performed after confirmation of safety, considering such areas as earthing, prevention of electric shock and other types of injury.
- 2) When equipment is to be removed, confirm the safety process as mentioned above. Cut air pressure and electrical power supplies which are the energy sources for the equipment and exhaust all residual compressed air in the system.
- 3) Before machinery/equipment is re-started, take measures to prevent short circuit, etc.

#### 4. Do not use product under the following conditions or environments. If it is not avoidable, take appropriate measure and contact SMC.

- 1) Conditions and environments beyond the given specifications or if product is to be used outdoors.
- 2) Installation on equipment in conjunction with atomic energy, railway, air navigation, vehicles, medical equipment, food and beverage, recreation equipment, emergency stop circuits, press applications or safety equipment.
- 3) An application, which has the possibility of having negative effects on people, property, or animals require a special safety analysis.

### Selection



### WARNING

#### 1. This product is intended for use in general factory automation systems.

If other applications (especially the ones indicated in section 4 above) are used, please contact SMC before use.

#### 2. Use within specified voltage and temperature limits.

Voltage out of specification may cause malfunction, damage, electric shock and/or fire.

#### 3. Use clean, compressed air for fluid.

Do not use flammable or explosive gas for fluid as it may cause fire or explosion. When fluids other than compressed air are used, please contact SMC service representative.

#### 4. This product does not have an explosion-proof construction.

Do not use this product in areas where dust explosion might be triggered or where flammable or explosive gas is present. It may cause explosion and/or fire.

 **CAUTION**

**1. This product has not been flushed.**

When using this product in a clean room environment, flush and confirm the product's purification level before use.

**Installation**

 **WARNING**

**1. Install only where there is adequate space for maintenance, wiring and piping.**

When installing the electrical connector and one touch pneumatic fitting, ensure sufficient room is left for easy insertion and removal of electrical cable and pneumatic tube.

Do not install with sharp bends in the cable or tube. With consideration of the minimum bend radii given below, ensure that cable and tube entries are straight, and do not apply stress to the electrical connectors or pneumatic fittings. If the connectors or fittings are subject to mechanical stress, malfunctions such as broken wires, air leaks or fire may occur.

Minimum bending radius: Power supply cable / Connection cable A.....35 mm

Sensor cable / Connection cable B.....25 mm

Note: These are minimum bend radii at 20°C. If installation is at a lower temperature, the values will be greater.

Refer to specific catalogue for the minimum bend radius of the pneumatic tube.

**2. Install only on a flat surface.**

A curved or uneven mounting surface may cause excessive force to be applied to the frame or case. This force, as well as a heavy impact (e.g. from dropping the Ionizer) may result in damage and failure.

**3. Do not use in areas subject to electrical noise.**

It may cause malfunction, deterioration or damage to internal components. Take measures to prevent noise at source and avoid power and signal lines from coming into close contact.

**4. Tighten with the specified torque.**

Refer to the following table for the correct tightening torque. If the tightening torque is exceeded the mounting screws and brackets may be broken. If the tightening torque is not reached, the mounting screws and brackets may become loose.

Screw size	Recommended tightening torque (N·m)
M3	0.61 to 0.63
M4	0.73 to 0.75
M5	1.3 to 1.5

**5. Do not touch the electrodes with a finger or metal tool directly. It may cause injury or malfunction.**

If the electrodes are touched with a finger, injury or damage may result or if the electrodes are touched with metal tools damage may result. This may interfere with the specified function and performance, but may also cause operational failure or accident.

 **Caution**  
for High Voltage

Do not touch the electrodes.  
High voltage is present.  
If foreign substances are inserted or persons come into contact with the electrodes, they may be injured by an electric shock or by trying to avoid one.

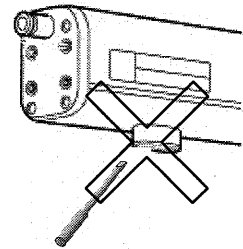
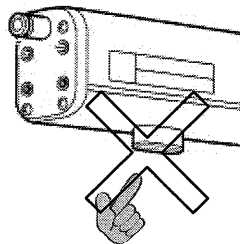

**6. Do not attach tape or seal to the product body.**

If conductive adhesive or reflective paint is contained in the tape or seal, dielectric phenomenon will occur due to the ions emitted by the ionizer and it may lead to electrostatic charge or electric leakage.

**7. Be sure to install or adjust only after power supply is stopped.**

 **CAUTION**

**1. Keep the minimum free space (as shown in the diagrams), around the Ionizer for correct operation, installation and maintenance.**

Walls or other objects that are present within the minimum free space area can interfere with the operation of the Ionizer, reducing the efficiency of static charge removal.

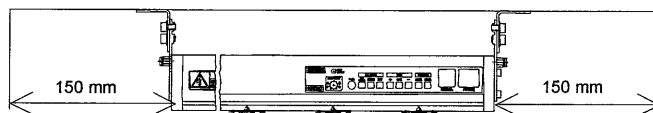
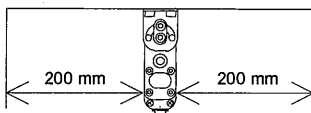

**2. Be sure to check the effect of static charge removal after installation.**

The effectiveness of static charge removal varies depending on the installation and operating conditions.

3. When placing the ionizer with the auto balance sensor [body mounting type] and another ionizer operated in DC mode adjacently, keep a distance of at least 2m between them.

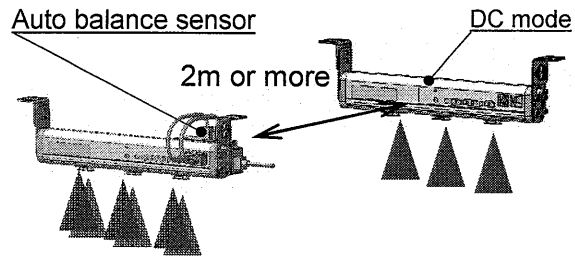

When using the ionizer with the auto balance sensor [body mounting type] near another ionizer operated in DC mode, separate them at a distance of 2m or more. If they are placed nearer, the ion discharge from the ionizer operated in DC mode can prevent precise adjustment of ion balance.

## Wiring and piping



### WARNING

1. Check the capacity of the power supply is enough and the voltage is within the specified range before wiring.
2. Be sure to use the UL listed power supply specified by NEC (National Electric Code) to be a class 2 output or the limited power source evaluated in accordance with UL 60950.
3. To maintain product performance, and to prevent electrical shock, connect a protective earth in accordance with instructions in this manual. Ensure that the resistance between the lead wire and ground is less than 100  $\Omega$ .
4. Be sure to turn off the power supply before wiring (including the removal and mounting of the connector).
5. When connecting the feedback sensor or auto balance sensor with the product, use the cable attached to the sensor and do not disassemble and modify them.
6. When turning on the power supply, check the wiring and ambient conditions for safety.
7. Do not remove or mount the connector wired to the power supply with the power supply on. Otherwise, the product can malfunction.
8. The connection in the same route as a power cable or high voltage cable can generate noise, causing the product to malfunction. Wire the product individually.
9. Be sure to check correct wiring before operating the product. Incorrect wiring may lead to damage to and malfunction of the product.
10. Flush piping before using. Also, pay attention not to let the dusts, water drops and oils get in and attach the product.

## Environment



### WARNING

#### 1. Use within operating fluid and ambient temperature range.

The operating fluid and ambient temperature range for Ionizer, feedback sensor and auto balance sensor is 0 to 50°C. In areas where sudden temperature changes occur, even when these changes are within the specified temperature range, condensation may form. The Ionizer should not be used in such conditions.

#### 2. Do not use this product in an enclosed space.

This product utilizes the corona discharge phenomenon. Since this process generates a small amount of ozone and NO<sub>x</sub>, only use the Ionizer in open, well-ventilated areas.

#### 3. Environments to avoid

Do not use or store under the following conditions, as these may cause equipment failure:

- Ambient temperatures outside the range 0 to 50°C.
- Ambient humidity outside the range 35 to 85% RH.
- Areas where rapid temperature changes may cause condensation.
- Areas where corrosive gas, flammable gas or other volatile flammable substances are stored.
- Areas where the product may be exposed to conductive powder, such as, iron powder or dust, oil mist, salt, organic solvent, machining chips, particles or cutting oil.
- Directly in the path of air conditioners.
- In enclosed, poorly ventilated areas.
- Exposed to the direct sunlight and/or radiant heat.
- Areas where strong electromagnetic noise is generated (strong electric or magnetic fields, large surges).
- Areas prone to electro-static discharge.
- Areas where RF noise is generated.
- Areas prone to lightning strikes.
- Areas where the product is directly exposed to vibration and/or impact.
- Subject to weight or mechanical stresses that could cause deformation of the product.

If any of these conditions are unavoidable, take appropriate protection measures.

**4. Do not use air containing mist or dust.**

Air containing mist or dust may lower function and shorten the maintenance cycle. Use a dryer (IDF series), air filter (AF/AFF series), and mist separator (AFM/AM series) to produce clean, compressed air.

**5. Ionizer, feedback sensor and auto balance sensor are not proof against lightning strikes.**

Protection against electrical surges due to lightning should be incorporated into the equipment.

**Maintenance**



**WARNING**

**1. Do not drop, hit an object or cause excessive impact (10G or more) when handling. Although externally the ionizer may not appear to be broken, there may be internal damage causing malfunction.**

**2. When the cable is inserted or removed, pinch modular plug spring clip with finger and insert or remove the plug in a straight line. If inserted or removed in an inappropriate direction, the mounting part of the modular jack might be damaged leading to operational failure.**



**CAUTION**



**Caution for High Voltage**

A high voltage generating circuit is installed. Ensure the supply voltage is removed before any maintenance is performed. Do not disassemble or modify the product as it may reduce efficiency of the functions and cause injury due to electric shock or electric leakage.

**1. Keep electrodes clean with regular maintenance.**

Make sure that the equipment is operating without any errors by regular maintenance. Only people with sufficient knowledge and experience should perform maintenance of the equipment. Contamination adhering to the electrodes, due to long operating periods, reduces the ability of the ionizer to eliminate static electricity. If, after cleaning the electrodes, the ionizer does not regain its correct performance, the electrodes should be replaced. In order to maintain stable performance, regular maintenance and cleaning of electrodes is recommended.

**2. The power supply must be removed when cleaning the electrodes, or changing the electrode cartridge.**

To avoid the risk of electric shock, do not touch the electrodes whilst the ionizer has power connected.

**3. Check there is no work piece when detecting the contamination of the electrode needle.**

The ionizer will be discharging ions while detecting the contamination of the electrode needle, and can charge the work piece.

**4. Do not open the case to disassemble and reconstruct the product.**

It may cause electric shock, operational failure and/or disaster, such as, fire. In addition, note the product, which is disassembled or reconstructed, may not satisfy the functions and performance in the specifications and is out of guarantee.

**5. Do not operate the product with wet hands.**

There is a danger of electric shock.

**2. Installation**

**2-1. Installation of Ionizer body**

Investigate the places where static problems occur, or places where processes and parts generate ESD (electro-static discharge), and carefully consider the required conditions to ensure appropriate static charge removal before installation.

**2-1-1. Installation height**

When the ionizer is installed, keep the distance between charged objects and the ionizer within the range below.

Ion-production frequency [Hz]	Distance between the charged objects and ionizer (mm)	
	With air purge (note)	Without air purge
1	400 to 2000	400 to 500
3	300 to 2000	300 to 400
5	300 to 2000	300 to 400
10	200 to 2000	200 to 300
15	200 to 2000	200 to 300
20	150 to 2000	150 to 250
30	50 to 2000	50 to 200
60	50 to 2000	50 to 150

Note: The installation heights stated above are nominal values; check the efficiency of operation before installation.

The minimum installation height should be greater than 200 mm when the feedback sensor is used.

When the auto balance sensor [high precision type] is used, the installation height should be greater than 100 mm.

When the ionizer is used outside of these conditions, ensure the correct operation of the sensors.

2-1-2. Mount end brackets on both sides of the ionizer body with the supplied M4 screws.

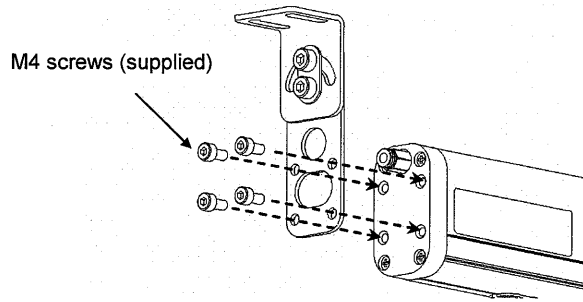

2-1-3. Mount intermediate brackets on the ionizer body at regular intervals.

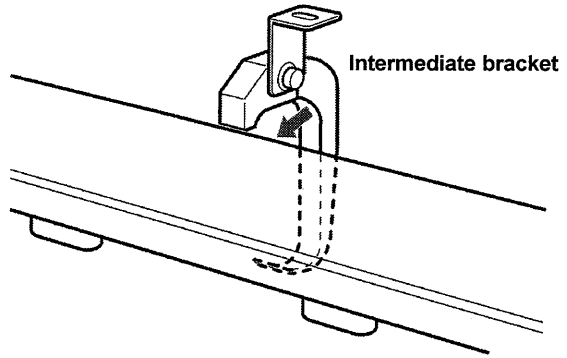

2-1-4. Tap M5 threads on the mounting positions of the brackets, and fix the ionizer body and brackets with M5 screws.

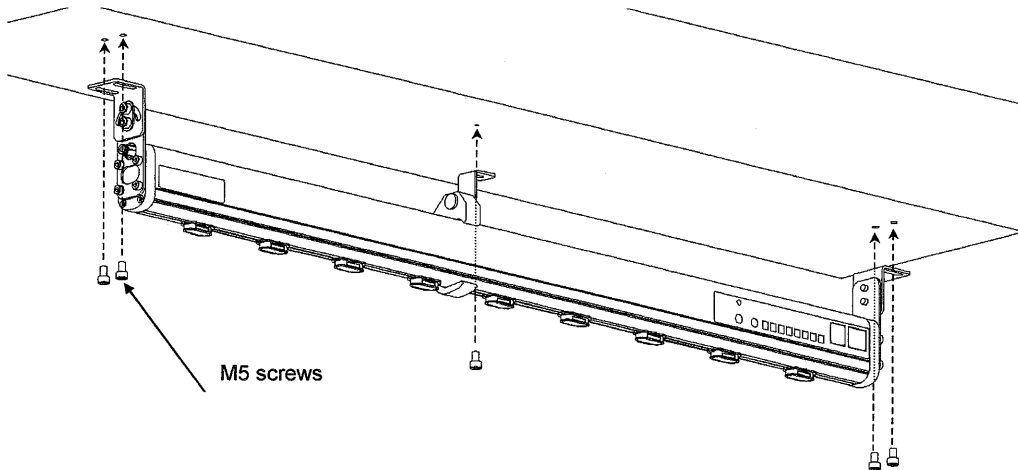

2-1-5. Adjust angle of the ionizer body to ensure proper static charge removal, and fix it in position with the bracket locking screws (M5).

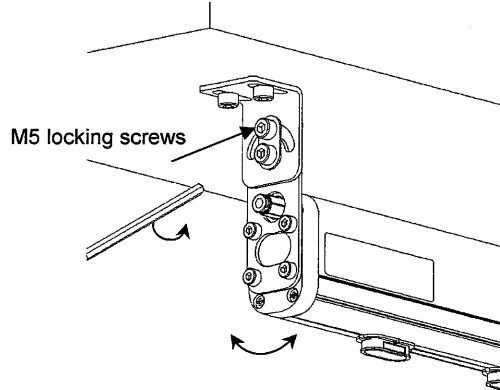

2-1-6. When using the auto balance sensor [high precision type] or no sensor is used : Ensure DC1(-)[blue] is connected to ground with a lead resistance of less than 100Ω. When using the auto balance sensor [body mounting type] is used : Ensure DC1(-)[blue] is connected to ground with a lead resistance of less than 100Ω, do not connect to power supply 0v. If these connections are not made correctly, the Ionizer may become damaged.

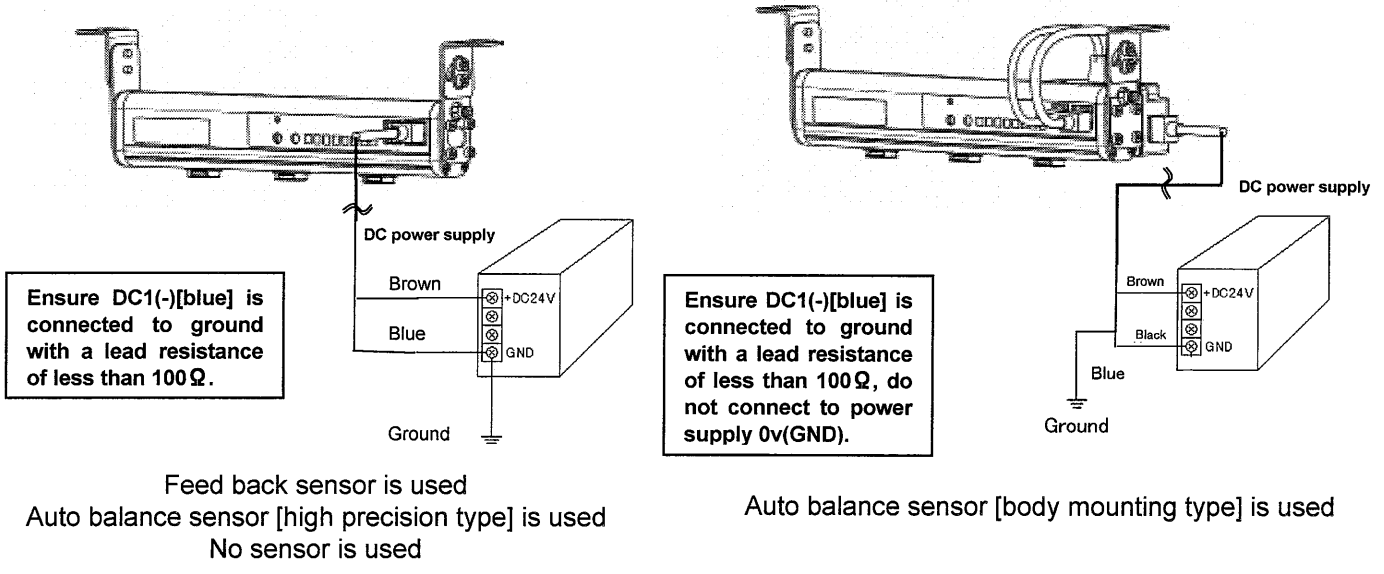

## 2-2. Installation of sensors

### 2-2-1. Installation of sensor head

#### Feedback sensor

Point the detecting hole of the sensor head towards the charged object to accurately measure the object's static charge. Ensure the distance between the detecting hole and surface of the charged object is between 10 and 50 mm. Do not allow the feedback sensor to come into contact with the charged object. The detecting area and sensor output will vary depending on the distance between the surface of the charged object and sensor.

Mount the sensor head with two off M3 screws (sold separately).

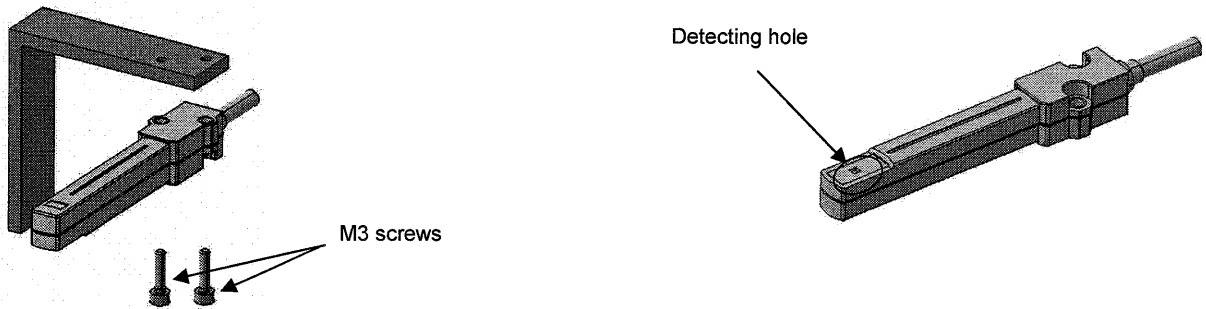

The sensor head case is connected to GND, therefore when installing the power supply, it is very important to take great care that there is not a short circuit between GND and 24V.

Do not insert foreign objects into the detecting hole. The detecting hole is open to enable the measurement of static electricity. If foreign objects, such as tools are inserted into it, the sensor will be damaged. The Ionizer will not function correctly with a damaged sensor.

Do not pull the cable out of the sensor head. If the cable is pulled with excessive force, the sensor head may be damaged.

#### Auto balance sensor [high precision type]

Position the auto balance sensor directly under the Ionizer, with its metal plate facing upwards. The ion balance will change depending on the installation height, so the sensor should be installed on a level as close as possible to that of the work-piece. The auto balance sensor can be removed once the ion balance adjustment is completed.

Keep the height between the auto balance sensor and Ionizer within the installation height stated in 2-1.

Mount the sensor head with 2 off M3 screws (sold separately).

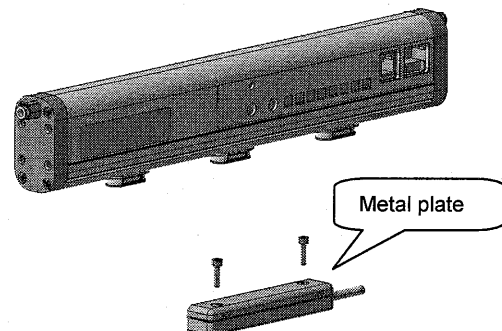



### 2-2-2. Installation of the sensor amplifier

The sensor amplifier should be fixed with 2 off M3 screws (sold separately).

Do not pull the cable out of the sensor amplifier. If the cable is pulled with excessive force, the amplifier may be damaged.

Ensure the case of the sensor amplifier is grounded (resistance between the lead wire and ground must be less than  $100\ \Omega$ ). The amplifier case surface is treated with conductive plating, therefore, when the mounting surface itself is grounded, it is not necessary to provide a separate connection to ground. If, however, the mounting surface is insulated (by paint or anodising for example), the case must be wired to ground.

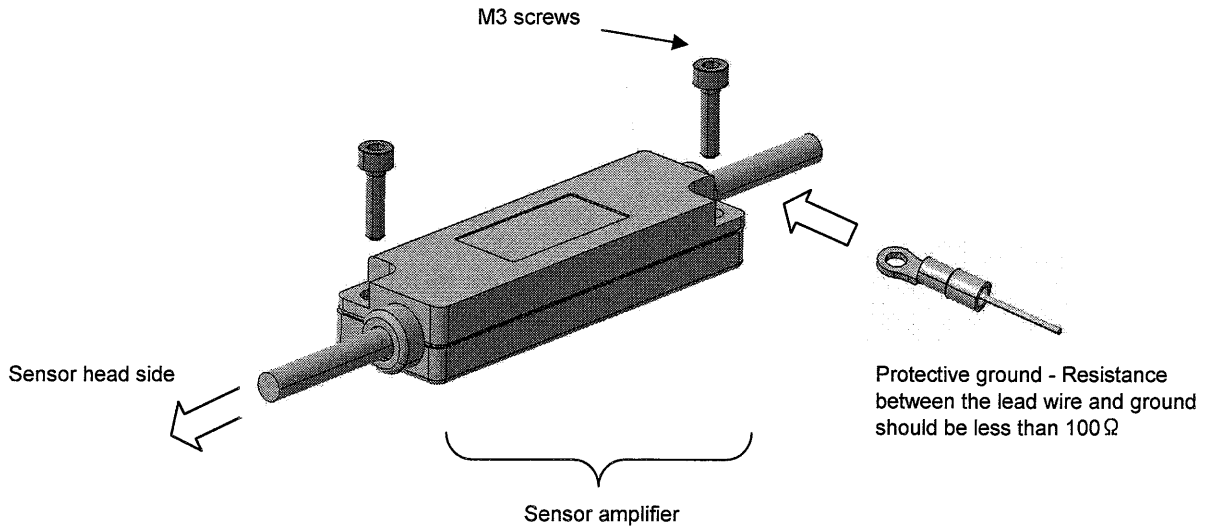

### Auto balance sensor [body mounting type]

Mount the sensor bracket (IZS31-BL) to the ionizer with 4 M4 screws, and mount the auto balance sensor to the sensor bracket with 2 M3 screws. Then, tighten to the end bracket (IZS31-BE).

Next, insert the modular plug of the power supply cable (IZS31-CP) into the modular jack "POWER IN" of the auto balance sensor.

Then, insert the modular plugs of the connection cable A (IZS31-CF) and connection cable B (IZS31-CR) to the following modular jacks respectively.

Connection cable A (IZS31-CF): "POWER OUT" of auto balance sensor and "POWER" of ionizer

Connection cable B (IZS31-CR): "SIGNALT" of auto balance sensor and ionizer

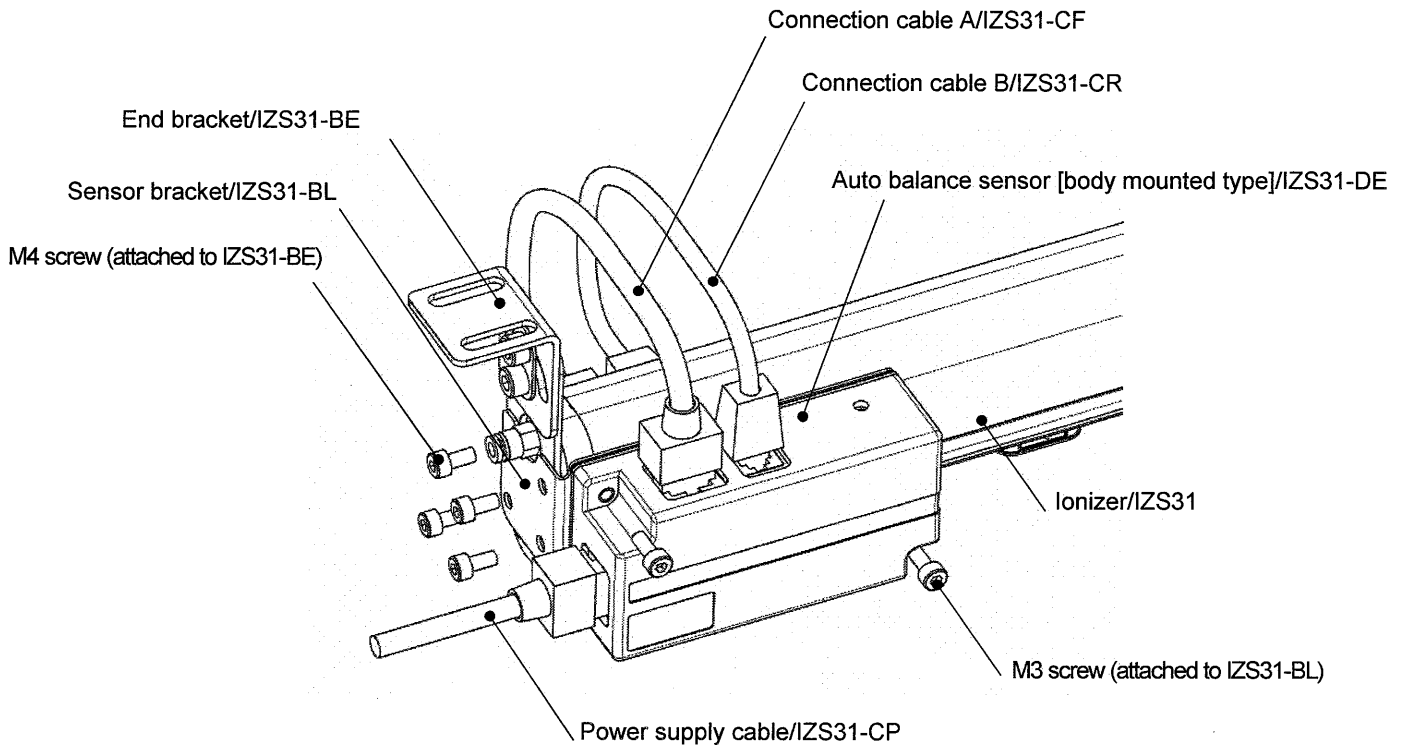

## 2-3. Connection of cables

2-3-1. Insert the modular plug of the power lead IZS31-CP into the modular jack on the ionizer body, as shown in the diagram.

When using the auto balance sensor [body mounting type], insert the modular plug of the power supply cable into the modular jack "POWER IN" of the auto balance sensor.

The spring clip will snap into place when the modular plug is correctly locked. When power is ON, the power indicator will light. Fix cables with a tie wrap or other measures to secure connection, preventing excessive force on the modular jack and plug.

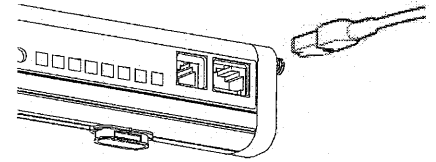

2-3-2. Connect the lead wires in accordance with the wiring table. (See Section 4). The unused wires should be cut short or covered with insulation tape without stripping the wire insulation to prevent them from coming into contact with other wires.

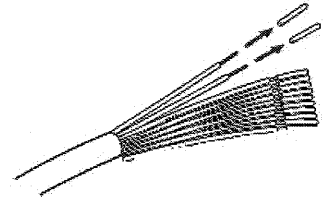

2-3-3. When a feedback sensor or auto balance sensor [high precision type and body mounting type] is used, remove the dust cover from the modular jack and insert the modular plug of the sensor cable. The spring clip will snap into place when the modular plug is correctly locked. When the ionizer is in use the signal indicator will light. Fix cables with a tie wrap or other measures to secure connection, preventing excessive force on the modular jack and plug.

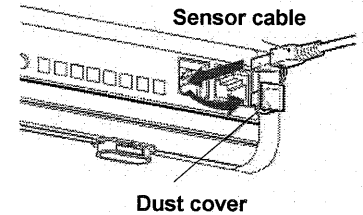

## 3. Function description

### 3-1. Operation mode

3 modes of operation are available with IZS31 (sensing DC mode, pulse DC mode and DC mode.) These modes are changeable depending on the application and operating conditions.

#### 3-1-1. Sensing DC mode

Sensing DC mode is suitable for objects that are highly charged.

In this mode, the charged condition of the work-piece is detected by the feedback sensor, this information is fed back to the ionizer and if the static charge of the work-piece is greater than  $\pm 30$  V, the ionizer will discharge ions with the appropriate polarity to remove static charge in the shortest possible time.

Whilst static charge removal is in progress, the completion signal is output.

When static charge removal is complete, the completion signal will turn off.

Once the static charge elimination is completed, [energy-saving operation] or [continuous static charge removal operation] can be selected.

Energy-saving operation	The ion discharge will automatically stop once static charge removal is completed. If the charge potential of the work increases to $\pm 30$ V or more, ion discharge will re-start. The [energy-saving operation] is recommended for conductive work-pieces.
Continuous static charge removal operation	The static charge will be continuously removed with pulse DC maintaining the ion balance to within $\pm 30$ V <sup>(note)</sup> even after the initial static charge removal is complete. The [continuous static charge removal operation] is recommended for nonconductive work-pieces.

Note: When the installation height of the feedback sensor is 25 mm.

#### 3-1-2. Pulse DC mode

The ionizer discharges positive and negative ions alternately.

When the auto balance sensor [high precision type] is used, the ion balance is automatically adjusted to within  $\pm 30$ V. If the ion balance exceeds  $\pm 30$ V due to contamination on the electrodes, the maintenance output signal will turn on and the maintenance indicator LED will flash.

When the auto balance sensor [body mounting type] is used, the ionizer will control to maintain initial setting of ion balance, and output maintenance signal if the ion balance is beyond its control due to the contamination of the electrode needle.

**When the auto balance sensor [high precision type] is used.**

[Manual operation] or [auto operation] can be selected for the ion balance adjustment.

Manual operation	When maintenance start-up signal is input, or the power supply of the ionizer is applied, the ion balance adjustment will begin. When work-pieces are moving, [manual operation] is recommended. Start the equipment after ion balance has been adjusted.
Auto operation	The ion balance is continuously adjusted. We recommend [auto operation] when removing static electricity of still work pieces and charged substances in a specific area.

**When the auto balance sensor [body mounting type] is used.**

When the auto balance [body mounting type] is used, the ionizer will control to maintain initial setting of ion balance, and output maintenance signal if the ion balance is beyond its control due to the contamination of the electrode needle. The setting of ion balance can be performed by the ion balance adjustable trimmer of the auto balance sensor.

※It is necessary to prepare an instrument to check the ion balance separately.

Ion balance adjustable trimmer

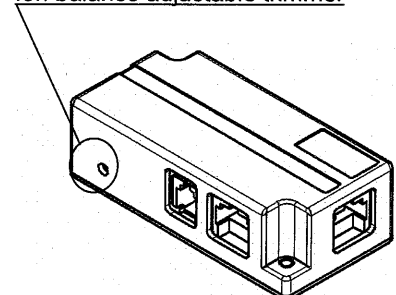

**When the auto balance sensor is not used.**

The ion balance is adjusted with the balance-adjusting trimmer. The ion balance needs to be measured by a separate instrument.

**3-1-3. DC mode**

Positive or negative ions are continuously discharged. Parts other than the charged object need to be grounded to prevent them from becoming charged. Positive and negative ions cannot be discharged simultaneously.

**3-2. Detection of contamination on the electrodes**

When the maintenance start-up signal is input, the ionizer carries out a self-check to see whether electrode contamination is causing a reduction in performance. If the self-check finds there is a reduction in performance, indicating the electrodes require cleaning, both the maintenance LED and the maintenance output signal will be turned on.

The use of the feedback or auto balance sensor [high precision type and body mounting type] alone will not show when the electrodes become contaminated. The maintenance start-up signal should be input regularly to check for optimum operation of the ionizer.

**3-3. Indication / Setting part description**

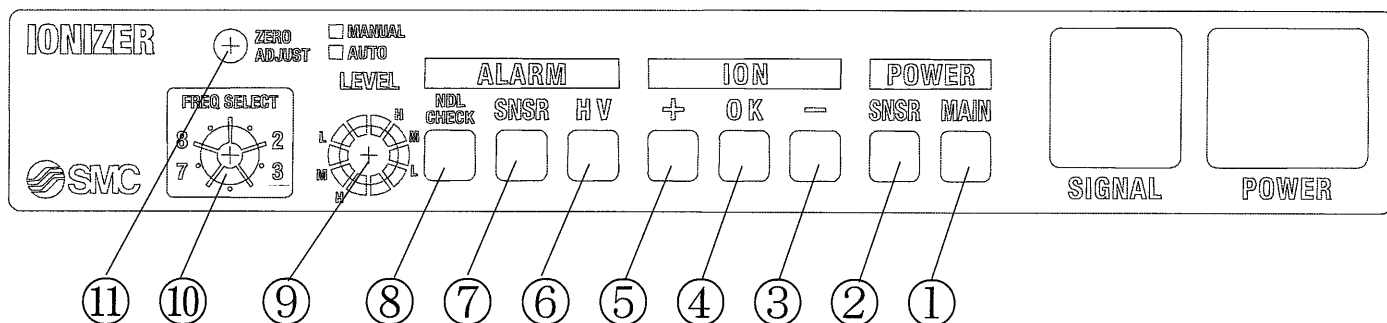

No.	Name	Type	Description
1	Power supply indicator	LED (Green)	Lights up when the power supply is turned ON. Flashes when the power supply voltage is out of specification.
2	Sensor connecting indicator	LED (Green)	Lights up when a feedback sensor and/or auto balance sensor [high precision type and body mounting type] is connected.
3	Negative indicator	LED (Blue)	LED will change depending on the operating mode. See section 4, the selection and setting of equipment.
4	Completion indicator	LED (Green)	
5	Positive indicator	LED (Orange)	
6	Indicator for abnormal high voltage	LED (Red)	Lights up when excessive electrode leakage current is detected.
7	Sensor failure indicator	LED (Red)	Lights up when the feedback sensor and/or auto balance sensor [high precision type] fails.
8	Maintenance indicator	LED (Red)	This indicates when maintenance is required by flashing when the electrodes are contaminated.
9	Maintenance level selecting switch	Rotary switch	Selected function's LED will light up when selected.
10	Frequency selecting switch	Rotary switch	See section 4, the selection and setting of equipment.
11	Balance adjusting trimmer	Trimmer	This trimmer is used to adjust the ion balance when the auto balance sensor [high precision type and body mounting type] is not used.

## 4. Selection and setting of equipment

### 4-1. Sensing DC mode

#### 4-1-1. Selection of bar length

Select the length applicable to work size based on static charge elimination area and static charge elimination characteristics.

#### 4-1-2. Installation of body

Keep the distance between the ionizer and charged objects within 200 to 2000 mm. Although the ionizer can be mounting outside of this range, it may not operate properly depending on the local conditions. Therefore, be sure to check that the ionizer will function correctly.

#### 4-1-3. Installation of the sensor

When installing the feedback sensor, point the detecting hole towards the charged face.

The sensor should be mounting within 10 to 50 mm of the object to be neutralized. Although the ionizer can be mounting outside of this range, it may not operate properly depending on the operating conditions. Therefore, be sure to check that the sensor will function correctly.

When the feedback sensor is connected to the ionizer, the operating mode automatically changes to sensing DC mode.

#### 4-1-4. LEVEL selector dial (maintenance level)

Contamination of the electrodes will impair the performance of the ionizer, so regular maintenance (cleaning) is recommended. The ionizer has a built-in function to detect contamination on the electrodes and inform the user when maintenance is required. Use the maintenance level selector dial to choose from three different detection levels:

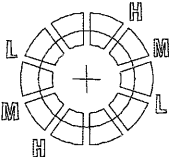
	H (High)	Notification will be before static charge elimination time is affected (very slight contamination will be detected)
	M (Middle)	Notification will be before there is a large change in static charge elimination time.
	L (Low)	Notification will be when the static charge elimination time is significantly longer than normal.

The contamination detection function is performed when the maintenance start-up signal is input.

#### 4-1-5. FREQ SELECT dial (energy saving or continuous elimination)

In sensing DC operation, there are two modes of use: Energy saving and continuous elimination.

Energy saving and continuous elimination modes only differ in function, after static charge has been removed from the work-piece.

In energy saving mode, when static charge removal is complete, the ionizer stops generating ions. As the ionizer is no longer emitting ions, power consumption is reduced.

In continuous elimination mode, when static charge elimination is complete, the ionizer continues to operate in pulse DC mode. The frequency of operation of pulse DC mode must be selected.

The FREQ SELECT dial is used to select which mode (and frequency), the ionizer will operate in.

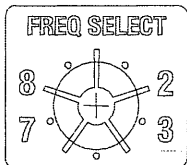

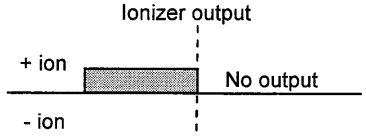
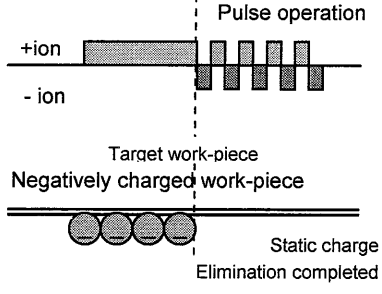
Mode	Operation details		Switch setting
Energy-saving mode	When the static charge elimination is complete, ion generation will cease.		8
Continuous elimination mode	When static charge elimination is complete, the ionizer will continue to operate in pulse DC mode. The ion balance will be maintained within +/-30V and ion generation will be at the selected frequency.		0 ••• 1 Hz 1 ••• 3 Hz 2 ••• 5 Hz 3 ••• 10 Hz 4 ••• 15 Hz 5 ••• 20 Hz 6 ••• 30 Hz 7 ••• 60 Hz

#### 4-1-6. Wiring tables

Connect dedicated power supply cables.

Connection details for ionizer operation

Symbol	Cable colour	Cable name	Connection	Description
DC1(+)	Brown	Power supply 24 VDC	○	Power supply for ionizer operation
DC1(-)	Blue	Power supply GND [FG]	○	
OUT4	Dark Green	Sensor monitor output	Δ	Analogue O/P (1 to 5V) proportional to static charge present on work-piece

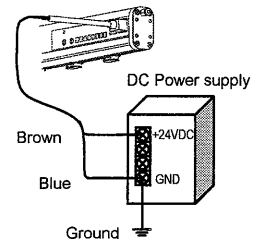

Be sure to ground DC1(-) [Blue]. To prevent possible damage to the ionizer, ensure that the resistance between the lead wire and ground is less than 100Ω.

Connection details for I/O signals

Symbol	Cable colour	Cable name	Connection	Description
DC2(+)	Red	Power supply 24 VDC	○	Power supply for I/O signal
DC2(-)	Black	Power supply GND	○	
IN1	Light Green	Discharge-stop signal	○	Signal for starting/ stopping ion generation (NPN type) Operation will begin when IN1 is connected with DC2(-)[Black]. (PNP type) Operation will begin when IN1 is connected with DC2(+)[Red].
IN2	Grey	Maintenance start-up signal	Δ	Input to begin a contamination level check of electrodes, and determine if cleaning is necessary.
-	White	-	-	-
-	Orange	-	-	-
OUT1	Pink	Completion signal for static charge elimination	Δ	Output is ON when the contamination of electrodes is being checked and when the static charge of the work-piece is outside of specification (+/- 30V).
OUT2	Yellow	Maintenance output signal	Δ	Output is ON when cleaning of electrodes is required.
OUT3	Purple	Failure signal	Δ	Output is ON if abnormally high voltage, and/or sensor, and/or CPU failure. (B contact output)

○ : Minimum number of wires required to operate the ionizer.

Δ : Wires required to operate the functions.

- : Wires not required for the sensing DC mode. These wires should not be short-circuited with other wires.

#### 4-1-7. Air piping

When only one port is piped, the other unused port should be plugged with the M-5P that is supplied with the ionizer.

#### 4-1-8. LED display

**POWER LED** ••• The power supply input and the connection of the sensors are displayed.

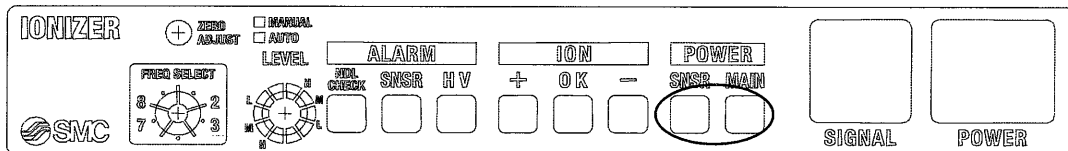

LED name	Functions
POWER	MAIN Lights up when the power supply is turned on. (Green) (Flashes when power supply is out of specification.)
	SNSR Lights up when the feedback sensor is connected.(Green)

**ION LED** ••• The charged condition of the work is displayed.

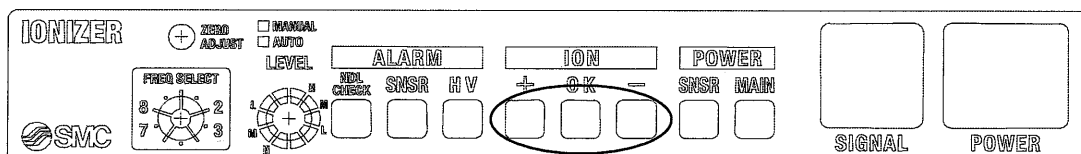

LED name	Functions
ION	+ The charged potential of the work is positive. (Orange)
	OK The charged potential of the work is low. (Green)
	- The charge potential of the work is negative. (Blue)

The charged condition of the work-piece can be identified from the LED display.

Charged polarity of work	LED			Charged potential of the work	■ Light on ■ Flashing at 4 Hz □ Light off
	+	OK	-		
Positive ↑ Static charge elimination ↓ Negative	■	□	□	More than +400 V	
	■	□	□	+100 V to +400 V	
	■	■	□	+30 V to +100 V	
	□	■	□	+30 V to -30 V	
	□	■	■	-30 V to -100 V	
	□	□	■	-100 V to -400 V	
	□	□	■	More than -400 V	

**ALARM LEDs** ••• Ionizer failure is displayed.

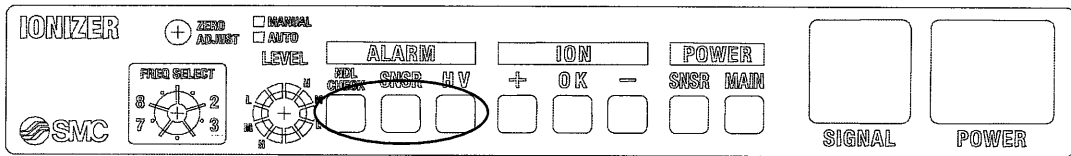

LED name		Functions
ALARM	HV	Lights up when excessive electrode leakage current is detected. (Red)
	SNSR	Lights up when the feedback sensor does not work correctly. (Red)
	NDL CHECK	Lights up when contamination on the electrodes is detected. (Red) (Flashes during the contamination detection process)

**4-1-9. Alarm**

Type of alarm	Description	How to reset
Abnormal high voltage	When over current on the high voltage line occurs. The ion discharge output is stopped. ALARM HV lights up and an alarm signal is output.	Turn off the power supply. Solve the problem. Once it is solved, turn on the power supply.  Or turn on and off the discharge-stop signal.
Sensor failure	When the feedback sensor fails. The ALARM SNSR lights up and an alarm signal is output.	
CPU failure	When the CPU fails due to noise. All ALARM LED's flash and an alarm signal is output.	
Electrode maintenance	When the electrodes require maintenance. The ALARM NDL CHECK lights up and an alarm signal is output.	Turn off the power supply and clean the electrodes. Then turn on the power supply.

**4-1-10. Timing chart**

Timing chart for normal operation

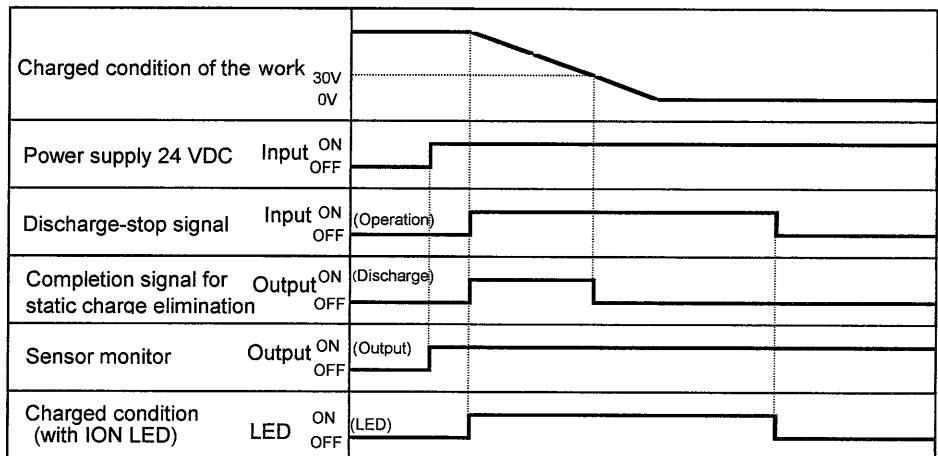

Timing chart when electrode contamination is detected

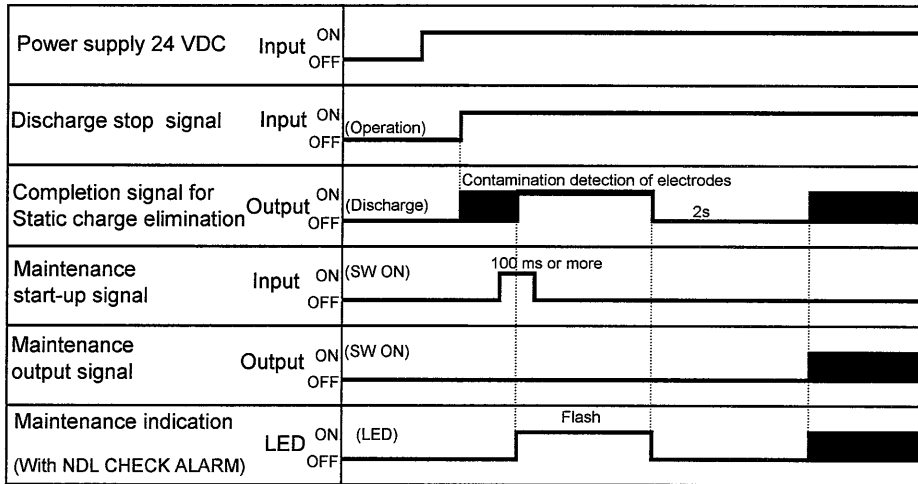

ON and OFF state will change depending on the situation

Whilst contamination on the electrodes is being detected, the completion signal for static charge elimination is output. Because ions are discharged from the ionizer when contamination is being detected, the work-piece might be charged. Therefore, the work-piece should not be mounting when detection is in progress.

## 4-2. Pulse DC mode

### 4-2-1. Selection of the bar length

Select an appropriate bar length that is suitable for the work size, static charge elimination characteristics and static charge elimination range.

### 4-2-2. Installation of the ionizer

Keep the distance between the ionizer and the charged object within 50 to 2000 mm. When the auto balance sensor [high precision type] is used, the distance should be between 100 to 2000 mm. When the ionizer is used outside of the specified conditions, operation may be affected. In this case, be sure to check that the ionizer will function correctly.

### 4-2-3. Installation of the sensor

#### When using the auto balance [high precision type]

Install the auto balance sensor [high precision type] to adjust the ion balance.

Place the auto balance sensor horizontally under the ionizer, and install the sensor [high precision type] on the same level as the work-piece.

When the auto balance sensor [high precision type] is connected, the balance adjustment trimmer is not used.

#### When using the auto balance [body mounting type]

When using the auto balance [body mounting type], fix it to the ionizer with the sensor bracket (IZS31-DE). Then, connect the connection cable A (IZS31-CF) and B (IZS31-CR) to the ionizer and auto balance sensor.

When the auto balance sensor [high precision type] is connected, the balance adjustment trimmer is not used.

### 4-2-4. LEVEL selector dial (maintenance level and auto-ion balance)

#### 4-2-4-1. Selection of mode of operation

##### When using the auto balance [high precision type]

When ion balance is adjusted using the auto balance sensor, either manual or auto mode can be selected

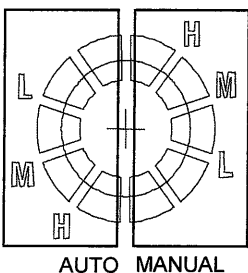

Mode	Description	Switch setting
Manual	Ion balance is adjusted when the maintenance start-up signal is input or when the power supply of the Ionizer is applied. The ion-balance adjustment values are retained for each ion-generation frequency. When the ion-generation frequency is changed, adjust the ion balance. Once the ion-balance adjustment is completed, the ion balance adjustment will not be repeated until the maintenance start-up signal is input again. Therefore, the auto balance sensor can be removed.	MANUAL
Auto	Ion-balance is continuously adjusted. If the auto balance sensor is removed, manually adjust the ion-balance with the balance adjustment trimmer.	AUTO

\* Position the dial in line with the desired detection level of electrode contamination.

**When using the auto balance [body mounting type]**

It is not necessary to select either AUTO or MANUAL with the maintenance level selector switch. When the auto balance sensor [body mounting type] is used, it acts to maintain the ion balance initially set. Use the ion balance adjustment trimmer on the auto balance sensor to adjust the ion balance manually.

When adjusting the ion balance, an instrument that can be used to measure the ion balance is needed.

The ion balance moves in a positive direction when the adjustment trimmer is rotated in clockwise manner, and in a negative direction when it is rotated in an anti-clockwise manner.

Ion balance adjustable trimmer

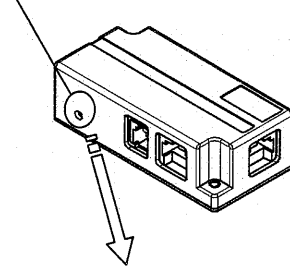

The trimmer can rotate up to 2 turns.

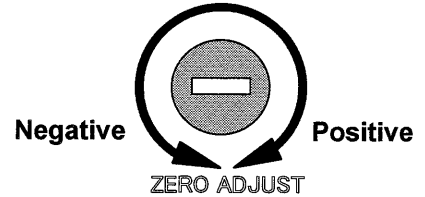

**When the ionizer is used without the auto balance sensor.**

When the auto balance sensor is not used, change the switch setting to AUTO, and manually adjust the ion-balance with the balance adjustment trimmer.

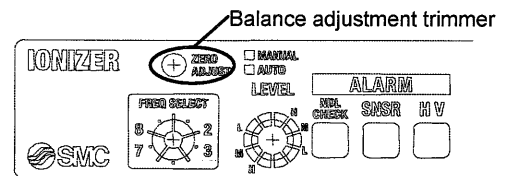

**4-2-4-2.**

The electrode contamination detection level must be set. Choose from three different levels: L (Low), M (Medium) or H (High).

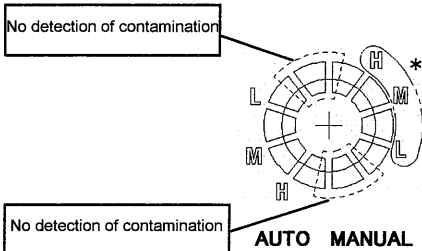

- H (High) Notification will be before static charge elimination time is affected (very slight contamination will be detected)
- M (Middle) Notification will be before there is a large change in static charge elimination time.
- L (Low) Notification will be when the static charge elimination time is significantly longer than normal.

※When using the auto balance sensor [high precision type], adjust the trimmer suitable for the operation mode of the sensor.

Ex.) When using the auto balance sensor [high precision type] and adjusting the ion balance in the manual operation mode, the maintenance level should be selected to be H, M and L at the "MANUAL" side.

The contamination detection function is performed when the maintenance start-up signal is input. If H, M and L levels are set, ion balance adjustment will be performed after the contamination detection.

**4-2-5. FREQ SELECT dial (ion generation frequency)**

The ionizer can operate over a range of several frequencies, to suit different applications. The desired ion generation frequency should be selected using the FREQ SELECT dial:

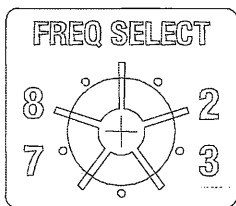

Ion-generation frequency (Hz)	Dial position
1	0
3	1
5	2
10	3
15	4
20	5
30	6
60	7



#### 4-2-6. Wiring tables

Connect dedicated power supply cables.

Connection details for ionizer operation

Symbol	Cable colour	Cable name	Connection		Description
			With high precision auto balance or no sensor	With body mounting type auto balance sensor	
DC1(+)	Brown	Power supply 24 VDC	○	—	Power supply for ionizer operation
DC1(-)	Blue	Power supply GND [FG]	○	○[FG only]	
OUT4	Dark Green	Sensor monitor output	—	—	—

※When using the auto balance sensor [high precision type] or no sensor is used : Ensure DC1(-)[blue] is connected to ground with a lead resistance of less than 100 Ω .

※When using the auto balance sensor [body mounting type] is used : Ensure DC1(-)[blue] is connected to ground with a lead resistance of less than 100 Ω , **do not connect to power supply 0v(GND)**.  
If these connections are not made correctly, the Ionizer may become damaged.

Connection details for I/O signals

Symbol	Cable colour	Cable name	Connection	Description
DC2(+)	Red	Power supply 24 VDC	○	Power supply for I/O signal
DC2(-)	Black	Power supply GND	○	
IN1	Light Green	Discharge-stop signal	○	Signal for starting/ stopping ion generation (NPN type) Operation will begin when IN1 is connected with DC2(-)[Black]. (PNP type) Operation will begin when IN1 is connected with DC2(+)[Red].
IN2	Grey	Maintenance start-up signal	Δ	Input to begin a contamination level check of electrodes, and determine if cleaning is necessary.
—	White	—	—	—
—	Orange	—	—	—
OUT1	Pink	Completion signal for static charge elimination	Δ	Output is ON when the contamination of electrodes is being checked.
OUT2	Yellow	Maintenance output signal	Δ	Output is ON when cleaning of electrodes is required.
OUT3	Purple	Failure signal	Δ	Output is ON if abnormally high voltage, and/or sensor, and/or CPU failure. (B contact output)

○ : Minimum number of wires required to operate the ionizer.

Δ : Wires required to operate the functions.

— : Wires not required for the pulse DC mode. These wires should not be short-circuited with other wires.

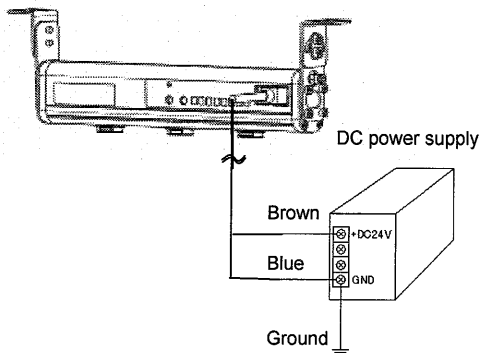

Feed back sensor is used  
Auto balance sensor [high precision type] is used  
No sensor is used

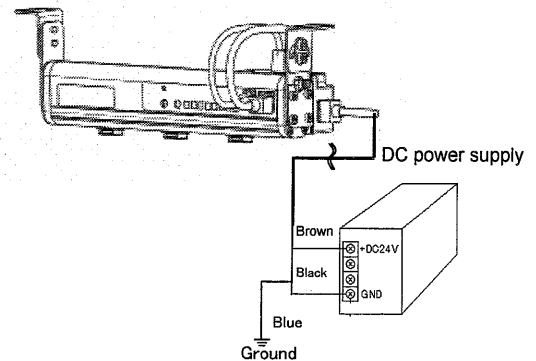

Auto balance sensor [body mounting type] is used

#### 4-2-7. Air piping

When only one port is piped, the other unused port should be plugged with the M-5P that is supplied with the ionizer.

#### 4-2-8. LED display

**POWER LED** ••• The power supply input and the connection of the sensors are displayed.

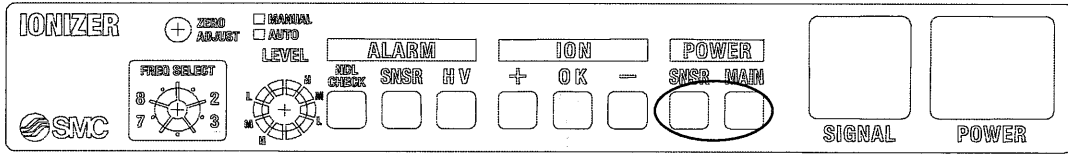

LED name		Functions
POWER	MAIN	Lights up when the power supply is turned on. (Green) (Flashes when power supply is out of specification.)
	SNSR	Lights up when the auto balance sensor is connected. (Green)

**ION LED** ••• The discharged ion polarity and ion balance are displayed.

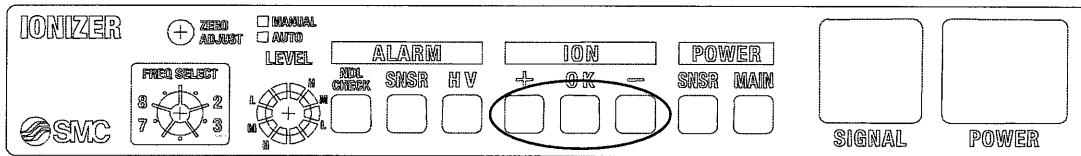

LED name		Functions
ION	+	Lights up when positive ions are generated. (Orange)
	OK	[With auto balance sensor] Shows the condition of ion balance (Green) (See ion balance table) [Without auto balance sensor] Light is off.
	-	Lights up when negative ions are generated. (Blue)

The ion balance state can be identified from the LED display.

Ion balance	OK LED
Within +/-30V	Lights up (or flashes)
Outside +/-30V	Light goes off

LED [OK] flashes when the ion balance nears the limits of the adjustment and indicates when maintenance of the electrodes is required.

**ALARM LEDs** ••• Ionizer failure is displayed.

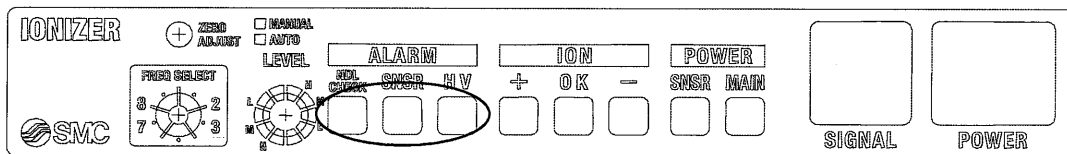

LED name		Functions
ALARM	HV	Lights up when excessive electrode leakage current is detected. (Red)
	SNSR	Lights up when the auto balance sensor [high precision type] does not function correctly. (Red)
	NDL CHECK	Lights up when contamination on the electrodes is detected. (Red) (Flashes during the contamination detection process)

#### 4-2-9. Alarm

Type of alarm	Description	How to reset
Abnormal high voltage	When over current on the high voltage line occurs. The ion discharge output is stopped. ALARM HV lights up and an alarm signal is output.	Turn off the power supply. Solve the problem. Once it is solved, turn on the power supply.  Or turn on and off the discharge-stop signal.
Sensor failure	When the auto balance sensor [high precision type] fails. The ALARM SNSR lights up and an alarm signal is output.	
CPU failure	When the CPU fails due to noise. All ALARM LED's flash and an alarm signal is output.	Turn off the power supply and clean the electrodes. Then turn on the power supply.
Electrode maintenance	When the electrodes require maintenance. The ALARM NDL CHECK lights up and an alarm signal is output.	

#### 4-2-10. Timing chart

Timing chart for normal operation

	Normal condition	Error condition	Remarks
Power supply DC24V input	ON OFF	ON OFF	The error signal (OUT3) can be reset by turning off the power supply and eliminating causes, and restarting the power supply. *Turning off and on the discharge stop signal (IN1) can be also used..
Discharge stop signal (IN1) input	(Operation) ON OFF	or ※ ON OFF	
Ion generating	ON OFF	ON OFF	
Error signal (OUT3) output	ON OFF	ON OFF	The signal will turn on in normal condition and turn off when error occurs.

#### Timing chart between electrode needle contamination detection and ion balance adjustment

(a) Auto balance sensor [body mounting type] connected

##### Manual operation

Power supply DC24V	Input	ON OFF	
Discharge-stop signal	Input	ON OFF	(Operation) 
Completion signal for Static charge elimination	Output	ON OFF	① 2s 
Maintenance Start-up signal	Input	ON OFF	(SW ON) 100 ms or more 
Maintenance Output signal	Output	ON OFF	(SW ON) 
Maintenance indication (NDL CHECK ALARM)	LED	ON OFF	(Lighting) 
Ionizer operation	Contamination detection of electrodes Adjust ion balance		Detection is executed when the maintenance level selecting switch, H, M or L is selected. 

##### Auto operation

Power supply 24 VDC	Input	ON OFF	
Discharge-stop signal	Input	ON OFF	(Operation) 
Completion signal for Static charge elimination	Output	ON OFF	(Contamination detection of electrodes.) 2s 
Maintenance Start-up signal	Input	ON OFF	(SW ON) 100 ms or 
Maintenance Output signal	Output	ON OFF	(SW ON) 
Maintenance indication (NDL CHECK ALARM)	LED	ON OFF	(Lighting) 
Ionizer operation	Contamination detection of electrodes Adjust ion balance		Detection is executed when the maintenance level selecting switch, H, M or L is selected. 

①(Contamination detection of electrodes or Ion balance adjustment)

(b) Auto balance sensor [body mounting type] connected

Power supply 24 VDC	Input	ON OFF	
Discharge-stop signal	Input	ON OFF	(Operation) 
Completion signal for Static charge elimination	Output	ON OFF	(Contamination detection of electrodes.) 2s 
Maintenance Start-up signal	Input	ON OFF	(SW ON) 100 ms or 
Maintenance Output signal	Output	ON OFF	(SW ON) 
Maintenance indication (NDL CHECK ALARM)	LED	ON OFF	(Lighting) 
Ionizer operation	Contamination detection of electrodes Adjust ion balance		Detection is executed when the maintenance level selecting switch, H, M or L is selected. 

(c) No sensor connected

Power supply 24 VDC	Input	ON OFF	
Discharge-stop signal	Input	ON OFF	(Operation) 
Completion signal for Static charge elimination	Output	ON OFF	(Contamination detection of electrodes.) 2s 
Maintenance Start-up signal	Input	ON OFF	(SW ON) 100 ms or 
Maintenance Output signal	Output	ON OFF	(SW ON) 
Maintenance indication (NDL CHECK ALARM)	LED	ON OFF	(Lighting) 
Ionizer operation	Contamination detection of electrodes Adjust ion balance		Detection is executed when the maintenance level selecting switch, H, M or L is selected. 

■ ON and OFF status will be changed depending on the situation.

Whilst contamination on the electrodes is being detected, the completion signal for static charge elimination is output. Because ions are discharged from the ionizer when contamination is being detected, the work-piece might be charged. Therefore, the work-piece should not be mounting when detection is in progress.

### 4-3. DC mode

#### 4-3-1. Selection of bar length

Select the length applicable to work size based on static charge elimination area and static charge elimination characteristics.

#### 4-3-2. Installation of body

Keep the distance between the ionizer and charged objects within 50 to 2000 mm. When the ionizer is used outside of the specified conditions, operation may be affected. In this case, be sure to check that the ionizer will function correctly.

#### 4-3-3. FREQ SELECT dial (polarity of emitted ions)

The ionizer can emit a constant stream of either positive or negative ions. Use the FREQ SELECT dial to select the desired polarity:

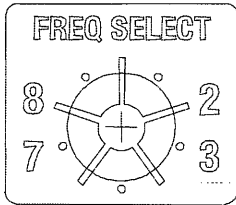

Ion discharge polarity	Dial position
Positive	8
Negative	9

#### 4-3-4. Wiring tables

Connect dedicated power supply cables.

Connection details for ionizer operation

Symbol	Cable colour	Cable name	Connection	Description
DC1(+)	Brown	Power supply 24 VDC	○	Power supply for ionizer operation
DC1(-)	Blue	Power supply GND [FG]	○	
OUT4	Dark Green	Sensor monitor output	-	-

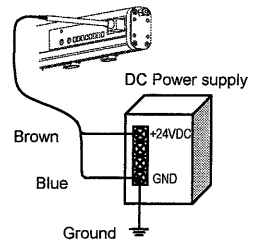

Be sure to ground DC1(-) [Blue]. To prevent possible damage to the ionizer, ensure that the resistance between the lead wire and ground is less than 100Ω.

Connection details for I/O signals

Symbol	Cable colour	Cable name	Connection	Description
DC2(+)	Red	Power supply 24 VDC	○	Power supply for I/O signal
DC2(-)	Black	Power supply GND	○	
IN1	Light Green	Discharge-stop signal	○	Signal for starting/ stopping ion generation (NPN type) Operation will begin when IN1 is connected with DC2(-)[Black]. (PNP type) Operation will begin when IN1 is connected with DC2(+)[Red].
IN2	Grey	Maintenance start-up signal	-	-
-	White	-	-	-
-	Orange	-	-	-
OUT1	Pink	Completion signal for static charge elimination	-	-
OUT2	Yellow	Maintenance output signal	-	-
OUT3	Purple	Failure signal	Δ	Output is ON if abnormally high voltage, and/or CPU failure. (B contact output)

○ : Minimum number of wires required to operate the ionizer.

Δ : Wires required to operate the functions.

- : Wires not required for the DC mode. These wires should not be short-circuited with other wires.

#### 4-3-5. Air piping

When only one port is piped, the other unused port should be plugged with the M-5P that is supplied with the ionizer.

#### 4-3-6. LED display

**POWER LED** ●●● The power supply input and the connection of the sensors are displayed.

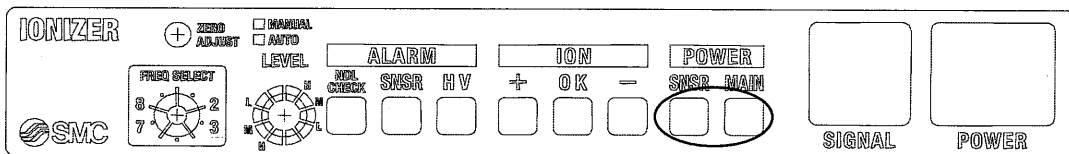

LED name		Functions
POWER	MAIN	Lights up when the power supply is turned on. (Green) (Flashes when power supply is out of specification.)
	SNSR	Light is OFF

ION LED ... The discharged ion polarity and ion balance are displayed.

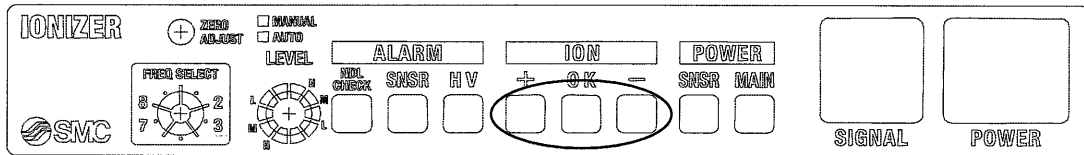

LED name		Functions
ION	+	Lights up when positive ions are generated. (Orange)
	OK	Light is OFF
	-	Lights up when negative ions are generated. (Blue)

ALARM LEDs ... Ionizer failure is displayed.

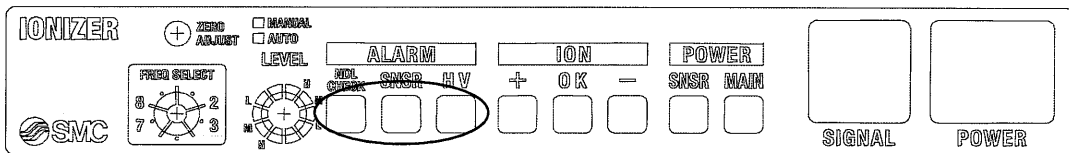

LED name		Functions
ALARM	HV	Lights up when excessive electrode leakage current is detected. (Red)
	SNSR	Light is OFF
	NDL CHECK	Light is OFF

#### 4-3-7. Alarm

Type of alarm	Description	How to reset
Abnormal high voltage	When over current on the high voltage line occurs. The ion discharge output is stopped. ALARM HV lights up and an alarm signal is output.	Turn off the power supply. Solve the problem. Once it is solved, turn on the power supply.
CPU failure	When the CPU fails due to noise. All ALARM LED's flash and an alarm signal is output.	Or turn on and off the discharge-stop signal.

#### 4-3-8. Timing chart

Timing chart for normal operation

	Normal condition	Error condition	Remarks
Power supply DC24V input	ON OFF	ON OFF	The error signal (OUT3) can be reset by turning off the power supply and eliminating causes, and restarting the power supply. *Turning off and on the discharge stop signal (IN1) can be also used..
Discharge stop signal (IN1) input	ON (Operation) OFF	ON OFF	
Ion generating	ON (Discharge) OFF	ON OFF	
Error signal (OUT3) output	ON OFF	ON OFF	The signal will turn on in normal condition and turn off when error occurs.

#### 4-4. Power supply cable connection circuit

① When the feedback sensor or Auto balance sensor [high precision type] is used.

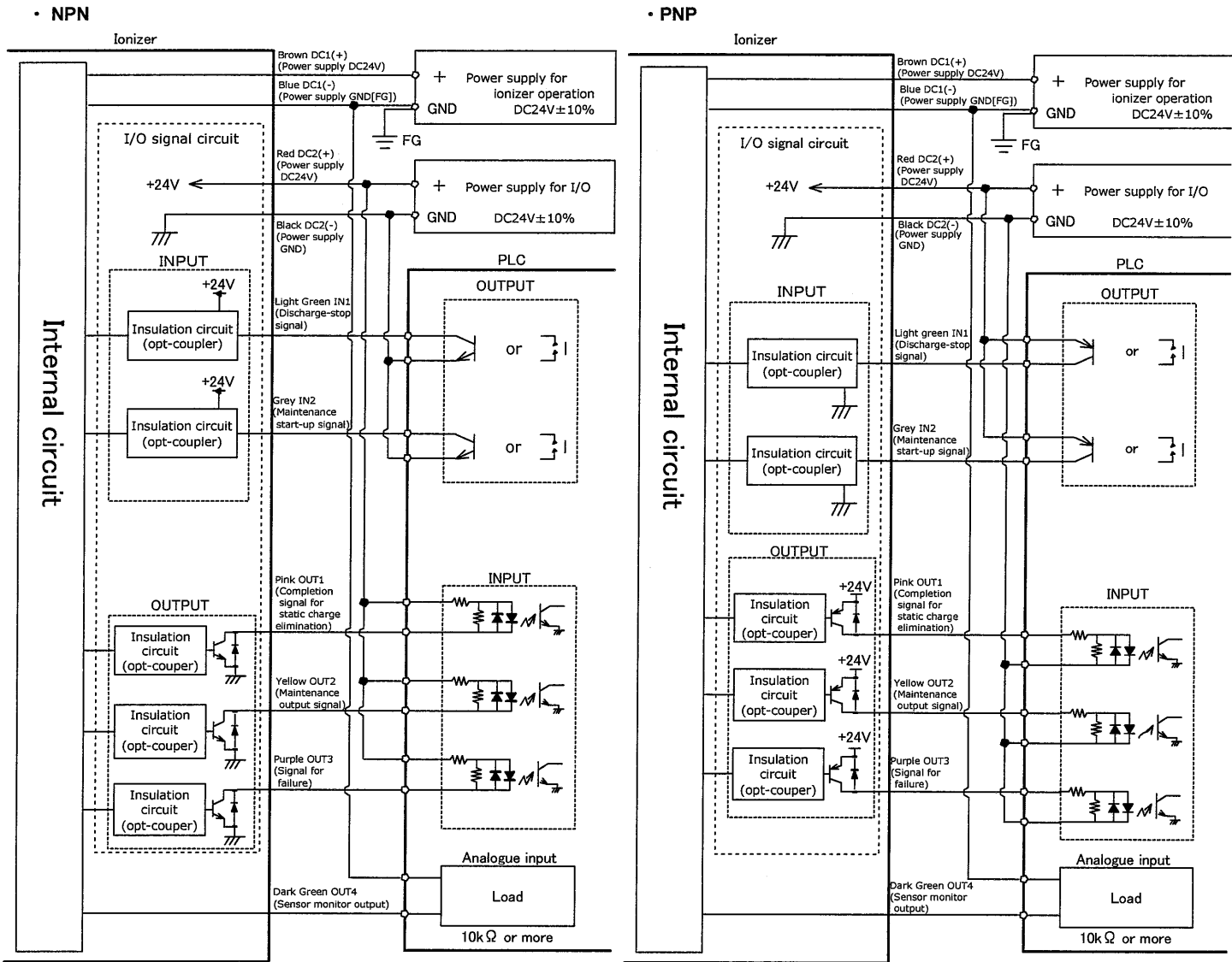

Note) The sensor monitor output (OUT4:Dark Green) is not isolated from the internal circuit of the ionizer; therefore, the return path is to ground (FG).

4-4-2. PNP

②Auto balance sensor [body mounting type] is used

• NPN

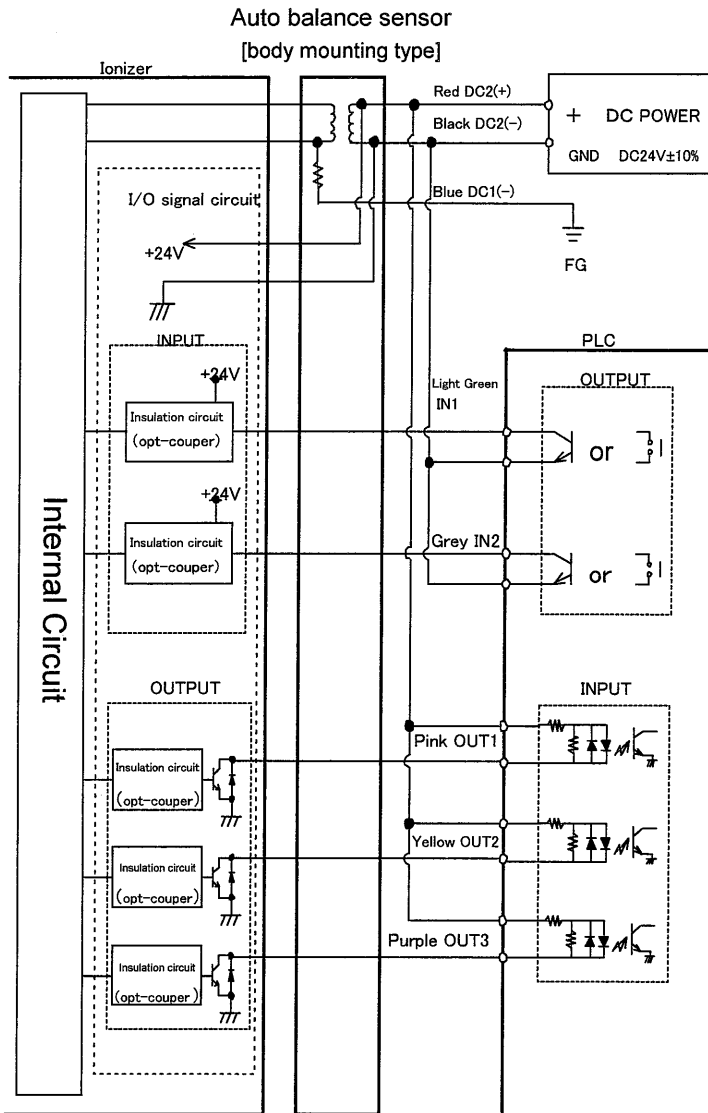

• PNP

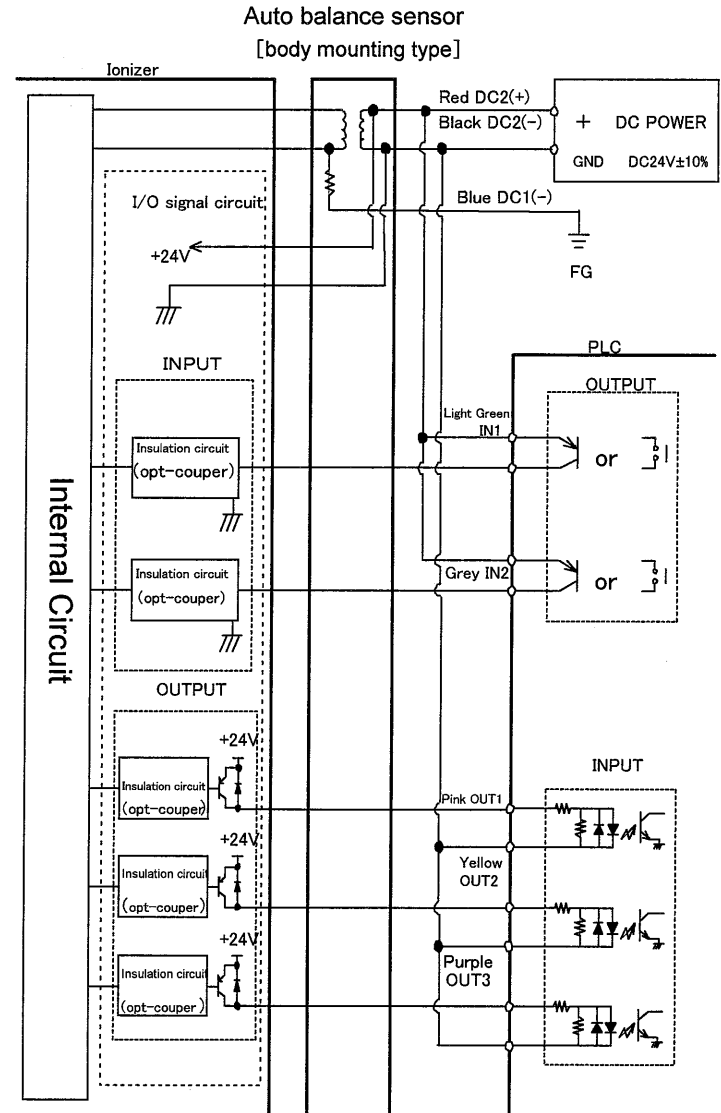

## 5. Specifications

### 5-1. Ionizer

※1: This value is applied when a distance between a charged target and the ionizer is at least 300mm and air purge is being conducted.

Model		IZS31 (NPN)	IZS31P (PNP)
Ion generation method		Colona discharge	
Voltage applying method		Sensing DC, Pulse DC, DC	
Discharge output		±7000V	
Ion balance* <sup>1</sup>		±30V (±100V for stainless electrode needle)	
Air purge	Fluid	Air (clean and dry)	
	Operating pressure	0.7MPa or less	
	Connected tube diameter	φ4	
Power supply voltage		24VDC±10%	
Current consumption	Sensing DC mode	200mA or less (120mA or less for stand-by)	
	Pulse DC mode	Auto balance sensor [high precision type] is used: 200mA or less Auto balance sensor [body mounting type] is used: 300mA or less No sensor is used: 170mA or less	
	DC mode	170mA or less	
Input signal	Discharge stop signal	Connected to GND (Voltage: 5VDC or less Current consumption: 5mA or less)	Connected to 24VDC (Voltage : Between 19VDC and power supply voltage , Current consumption: 5mA or less)
	Maintenance start signal		
Output signal	Electricity removal completion signal	Max. load current: 100mA Residual voltage: 1 or less (at load current 100mA)	Max. load current: 100mA Residual voltage: 1V or less (at load current 100mA)
	Maintenance output signal		
	Error signal	Max. applied voltage: 28VDC	
	Sensor monitor output* <sup>2</sup>	Voltage output 1 to 5V (A load of at least 10kΩ should be connected)	
Effective electricity removal distance		50 to 200mm (sensing DC mode: 200 to 2000mm)	
Fluid and ambient temp.		0 to 50°C	
Ambient humidity		35 to 80%RH (no condensation)	
Material		Ionizer cover: ABS Electrode needle: Tungsten, Single crystal silicone, Stainless	
Vibration resistance		Applied at 50Hz, 1mm amplitude for 2 hours in each of X, Y and Z direction	
Impact resistance		10G	
Applicable standards and directives		CE (EMC directive: 2004/108/EC) UL (U.S. Standard for Electrostatic Air Cleaners, UL867, fourth edition) CSA (Canadian Standard for Electrostatic Air Cleaners, CAN/CSA C22.2 No.187-M1986)	

※2: If the potential of a charged target is measured by the feedback sensor, the relation between the potential and the output voltage of the sensor monitor output and the detection range of the sensor will depend on the installation distance of the sensor.

[No. of electrode cartridge and weight]

Bar length [mm]	300	380	620	780	1100	1260	1500	1900	2300
No. of electrode cartridge	3	4	7	9	13	15	18	23	28
Weight [g]	330	400	600	720	1000	1100	1500	2000	2500



## 5-2 Sensor

Model	IZS31-DF Feedback sensor	IZS31-DG Auto balance sensor [high precision type]	IZS31-DE Auto balance sensor [body mounting type]
Ambient temp.	0 to 50°C		
Ambient humidity	35 to 80%RH (no condensation)		
Case material	ABS	ABS, Stainless	ABS
Vibration resistance	Applied at 50Hz, 1mm amplitude for 2 hours in each of X, Y and Z direction		
Impact resistance	10g		
Weight	200g (including cable)	220g (including cable)	110g (including cable)
Installation distance	10 to 50mm	-	
Applicable standards and directives	CE (EMC 2004/108/EC)		

### 5-2-1. Sensor monitor output (When feedback sensor is used)

**Relation of sensor output and charge potential with differing installation distances**

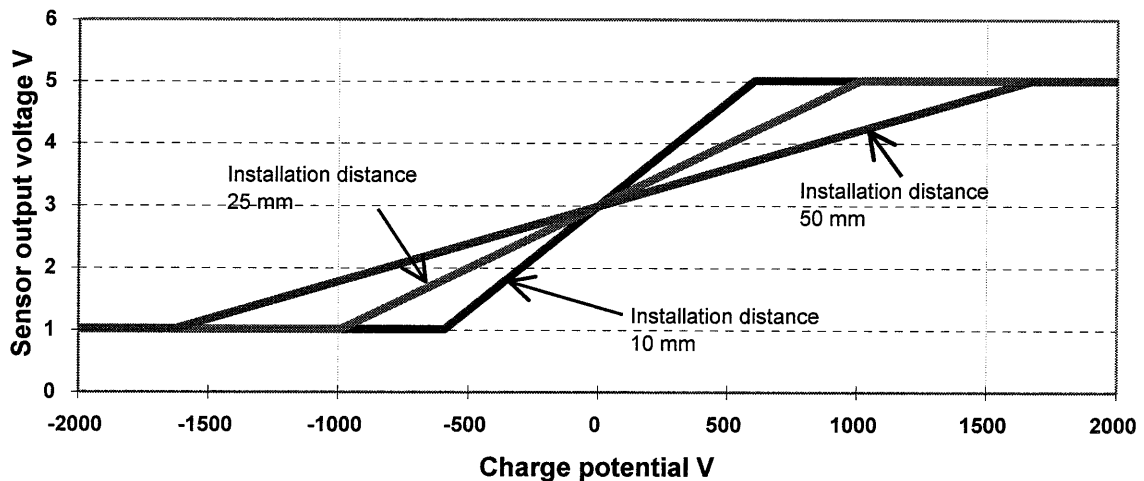

### 5-2-2. Detection range of Feedback sensor

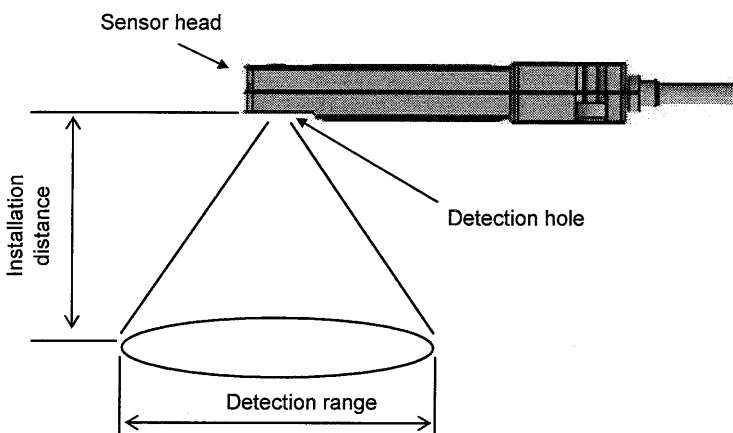

Installation distance (mm)	Detection range (mm)
10	45
25	100
50	180